



Bid Number/बोली क्रमांक (बिड संख्या):
GEM/2024/B/5028004
Dated/दिनांक : 14-06-2024

Bid Document/ बिड दस्तावेज़

Bid Details/बिड विवरण	
Bid End Date/Time/बिड बंद होने की तारीख/समय	15-07-2024 11:00:00
Bid Opening Date/Time/बिड खुलने की तारीख/समय	15-07-2024 11:30:00
Bid Offer Validity (From End Date)/बिड पेशकश वैधता (बंद होने की तारीख से)	120 (Days)
Ministry/State Name/मंत्रालय/राज्य का नाम	Ministry Of Finance
Department Name/विभाग का नाम	Department Of Economic Affairs
Organisation Name/संगठन का नाम	Security Printing And Minting Corporation Of India Limited (spmci)
Office Name/कार्यालय का नाम	Janpath
Item Category/मद केटेगरी	Custom Bid for Services - 452176
Contract Period/अनुबंध अवधि	6 Month(s) 4 Day(s)
Past Experience of Similar Services required/इसी तरह की सेवाओं का पिछला आवश्यक अनुभव है	Yes
MSE Exemption for Years Of Experience/अनुभव के वर्षों से एमएसई छूट/ and Turnover/टर्नओवर के लिए एमएसई को छूट प्राप्त है	Yes
Startup Exemption for Years of Experience and Turnover/ अनुभव के वर्षों से स्टार्टअप छूट	No
Document required from seller/विक्रेता से मांगे गए दस्तावेज़	Experience Criteria *In case any bidder is seeking exemption from Experience / Turnover Criteria, the supporting documents to prove his eligibility for exemption must be uploaded for evaluation by the buyer
Bid to RA enabled/बिड से रिवर्स नीलामी सक्रिय किया	No
Type of Bid/बिड का प्रकार	Two Packet Bid
Time allowed for Technical Clarifications during technical evaluation/तकनीकी मूल्यांकन के दौरान तकनीकी स्पष्टीकरण हेतु अनुमत समय	2 Days
Estimated Bid Value/अनुमानित बिड मूल्य	452176
Evaluation Method/मूल्यांकन पद्धति	Total value wise evaluation

EMD Detail/ईएमडी विवरण

Required/आवश्यकता	No
-------------------	----

ePBG Detail/ईपीबीजी विवरण

Required/आवश्यकता	No
-------------------	----

Splitting/विभाजन

Bid splitting not applied/बोली विभाजन लागू नहीं किया गया.

MII Compliance/एमआईआई अनुपालन

MII Compliance/एमआईआई अनुपालन	Yes
-------------------------------	-----

MSE Purchase Preference/एमएसई खरीद वरीयता

MSE Purchase Preference/एमएसई खरीद वरीयता	Yes
---	-----

1. If the bidder is a Micro or Small Enterprise as per latest definitions under MSME rules, the bidder shall be exempted from the requirement of "Bidder Turnover" criteria and "Experience Criteria" subject to meeting of quality and technical specifications. If the bidder is OEM of the offered products, it would be exempted from the "OEM Average Turnover" criteria also subject to meeting of quality and technical specifications. In case any bidder is seeking exemption from Turnover / Experience Criteria, the supporting documents to prove his eligibility for exemption must be uploaded for evaluation by the buyer.

2. Purchase preference will be given to MSEs having valid Udyam Registration and whose credentials are validated online through Udyam Registration portal as defined in Public Procurement Policy for Micro and Small Enterprises (MSEs) Order, 2012 dated 23.03.2012 issued by Ministry of Micro, Small and Medium Enterprises and its subsequent Orders/Notifications issued by concerned Ministry. If the bidder wants to avail themselves of the Purchase preference, the bidder must be the manufacturer / OEM of the offered product on GeM. Traders are excluded from the purview of Public Procurement Policy for Micro and Small Enterprises and hence resellers offering products manufactured by some other OEM are not eligible for any purchase preference. In respect of bid for Services, the bidder must be the Service provider of the offered Service. Relevant documentary evidence in this regard shall be uploaded along with the bid in respect of the offered product or service and Buyer will decide eligibility for purchase preference based on documentary evidence submitted, while evaluating the bid. If L-1 is not an MSE and MSE Seller (s) has / have quoted price within L-1+ 15% (Selected by Buyer) of margin of purchase preference /price band defined in relevant policy, such MSE Seller shall be given opportunity to match L-1 price and contract will be awarded for % (selected by Buyer) percentage of total quantity. The buyers are advised to refer the OM No. F.1/4/2021-PPD dated 18.05.2023 [OM_No.1_4_2021_PPD_dated_18.05.2023](#) for compliance of Concurrent application of Public Procurement Policy for Micro and Small Enterprises Order, 2012 and Public Procurement (Preference to Make in India) Order, 2017. Benefits of MSE will be allowed only if seller is validated on-line in GeM profile as well as validated and approved by Buyer after evaluation of documents submitted.

3. Estimated Bid Value indicated above is being declared solely for the purpose of guidance on EMD amount and for determining the Eligibility Criteria related to Turn Over, Past Performance and Project / Past Experience etc. This has no relevance or bearing on the price to be quoted by the bidders and is also not going to have any impact on bid participation. Also this is not going to be used as a criteria in determining reasonableness of

quoted prices which would be determined by the buyer based on its own assessment of reasonableness and based on competitive prices received in Bid / RA process.

4. Past Experience of Similar Services: The bidder must have successfully executed/completed similar Services over the last three years i.e. the current financial year and the last three financial years(ending month of March prior to the bid opening): -

1. Three similar completed services costing not less than the amount equal to 40% (forty percent) of the estimated cost; or
2. Two similar completed services costing not less than the amount equal to 50% (fifty percent) of the estimated cost; or
3. One similar completed service costing not less than the amount equal to 80% (eighty percent) of the estimated cost.

Additional Qualification/Data Required/अतिरिक्त योग्यता /आवश्यक डेटा

GEM Availability Report (GAR):[1717830449.pdf](#)

Undertaking of Competent Authority is mandatory to create Custom Bid for Services. Please download standard format document and upload:[1717830461.pdf](#)

Payment Terms:[1717850060.pdf](#)

Scope of Work:[1717850072.pdf](#)

Any other Documents As per Specific Requirement of Buyer -1:[1717850142.pdf](#)

Any other Documents As per Specific Requirement of Buyer -2:[1718339865.pdf](#)

Custom Bid For Services - 452176 (1)

Technical Specifications/तकनीकी विशिष्टियाँ

Specification	Values
Core	
Description /Nomenclature of Service Proposed for procurement using custom bid functionality	452176
Regulatory/ Statutory Compliance of Service	YES
Compliance of Service to SOW, STC, SLA etc	YES
Addon(s)/एडऑन	

Additional Specification Documents/अतिरिक्त विशिष्टि दस्तावेज़

Consignees/Reporting Officer/परेषिती/रिपोर्टिंग अधिकारी

S.No./क्र. सं.	Consignee Reporting/Officer/ परेषिती/रिपोर्टिंग अधिकारी	Address/पता	The quantity of procurement "1" indicates Project based or Lumpsum based hiring.	Additional Requirement/अतिरिक्त आवश्यकता
----------------	---	-------------	--	--

S.No./क्र. सं.	Consignee Reporting/Officer/ परेषिती/रिपोर्टिंग अधिकारी	Address/पता	The quantity of procurement "1" indicates Project based or Lumpsum based hiring.	Additional Requirement/अतिरिक्त आवश्यकता
1	Anurag Sharma	461005,Security Paper Mill ,Narmadapuram , Madhya Pradesh	1	N/A

Buyer Added Bid Specific Terms and Conditions/क्रेता द्वारा जोड़ी गई बिड की विशेष शर्तें

1. Buyer Added Bid Specific Scope Of Work(SOW)

Text Clause(s)

1. Scope of Work

Hiring an agency for repairing of 2 no.s of PVA tank

PVA Storage Tank, 1 No.

PVA Transfer Tank, 1 No.

1. Removal of cover plate and insulation
2. Removal of damaged ss plate.
3. Removal of damaged copper tube (15mm*1mm)
4. Cleaning of both Outside & Inside body of tank.
5. Fixing of copper tube (Appx length 30 mtr for 1 tank) copper tube should be on single length to avoided joints
6. Fixing of SS plate (size appx 3000*1500*2 mm) apx 2 plates for 1 tank

All consumables like: welding electrode, gas cylinder, SS 316 plate (Thickness- 2mm), Copper tube (Diameter-15mm, Thickness-1mm) etc are in scope of vendor

2. DRAWING

DRG PM#5/158 (for storage tank) attached for reference purpose.

3. Firm may visit SPM for any technical clarification.

4. Delivery: FOR SPM, Narmadapuram within 90 days of issue of contract in GeM

5. Payment: 100% on receipt and acceptance of goods by the consignee and on production of all required documents by the supplier.

6. Warranty:

6.1: The repairing work will be covered under warranty which shall remain valid for twelve months after the goods or any portion thereof as the case may be, have been delivered to the final destination and installed and commissioned at the final destination and accepted by SPM, Narmadapuram in terms of the contract.

6.2: In case of any claim arising out of this warranty, SPM, Narmadapuram shall promptly notify the same in writing to the supplier. Upon receipt of such notice, the supplier shall, with all reasonable speed, repair or replace the defective goods or parts thereof, free of cost, at the ultimate destination. The supplier shall take over the replaced parts/ goods after providing their replacements and no claim, whatsoever shall lie on SPMN for such replaced parts/ goods thereafter.

6.3: In the event of any rectification of a defect or replacement of any defective goods during the warranty period, the warranty for the rectified/ replaced goods shall be extended to a further period of twelve months from the date such rectified / replaced goods starts functioning to the satisfaction of SPMN.

6.4: If the supplier, having been notified, fails to rectify/ replace the defect(s) within a reasonable period, SPMN may proceed to take such remedial action(s) as deemed fit by SPMN, at the risk and expense of the supplier and without prejudice to other contractual rights and remedies, which SPMN may have against the supplier.

Disclaimer/अस्वीकरण

The additional terms and conditions have been incorporated by the Buyer after approval of the Competent Authority in Buyer Organization, whereby Buyer organization is solely responsible for the impact of these clauses on the bidding process, its outcome, and consequences thereof including any eccentricity / restriction arising in the bidding process due to these ATCs and due to modification of technical specifications and / or terms and conditions governing the bid. If any clause(s) is / are incorporated by the Buyer regarding following, the bid and resultant contracts shall be treated as null and void and such bids may be cancelled by GeM at any stage of bidding process without any notice:-

1. Definition of Class I and Class II suppliers in the bid not in line with the extant Order / Office Memorandum issued by DPIIT in this regard.
2. Seeking EMD submission from bidder(s), including via Additional Terms & Conditions, in contravention to exemption provided to such sellers under GeM GTC.
3. Publishing Custom / BOQ bids for items for which regular GeM categories are available without any Category item bunched with it.
4. Creating BoQ bid for single item.
5. Mentioning specific Brand or Make or Model or Manufacturer or Dealer name.
6. Mandating submission of documents in physical form as a pre-requisite to qualify bidders.
7. Floating / creation of work contracts as Custom Bids in Services.
8. Seeking sample with bid or approval of samples during bid evaluation process. (However, in bids for [attached categories](#), trials are allowed as per approved procurement policy of the buyer nodal Ministries)
9. Mandating foreign / international certifications even in case of existence of Indian Standards without specifying equivalent Indian Certification / standards.
10. Seeking experience from specific organization / department / institute only or from foreign / export experience.
11. Creating bid for items from irrelevant categories.
12. Incorporating any clause against the MSME policy and Preference to Make in India Policy.

13. Reference of conditions published on any external site or reference to external documents/clauses.
14. Asking for any Tender fee / Bid Participation fee / Auction fee in case of Bids / Forward Auction, as the case may be.
15. Any ATC clause in contravention with GeM GTC Clause 4 (xiii)(h) will be invalid. In case of multiple L1 bidders against a service bid, the buyer shall place the Contract by selection of a bidder amongst the L-1 bidders through a Random Algorithm executed by GeM system.

Further, if any seller has any objection/grievance against these additional clauses or otherwise on any aspect of this bid, they can raise their representation against the same by using the Representation window provided in the bid details field in Seller dashboard after logging in as a seller within 4 days of bid publication on GeM. Buyer is duty bound to reply to all such representations and would not be allowed to open bids if he fails to reply to such representations.

This Bid is governed by the [General Terms and Conditions/सामान्य नियम और शर्तें](#), conditions stipulated in Bid and [Service Level Agreement](#) specific to this Service as provided in the Marketplace. However in case if any condition specified in General Terms and Conditions/सामान्य नियम और शर्तें is contradicted by the conditions stipulated in Service Level Agreement, then it will over ride the conditions in the General Terms and Conditions.

In terms of GeM GTC clause 26 regarding Restrictions on procurement from a bidder of a country which shares a land border with India, any bidder from a country which shares a land border with India will be eligible to bid in this tender only if the bidder is registered with the Competent Authority. While participating in bid, Bidder has to undertake compliance of this and any false declaration and non-compliance of this would be a ground for immediate termination of the contract and further legal action in accordance with the laws./जेम की सामान्य शर्तों के खंड 26 के संदर्भ में भारत के साथ भूमि सीमा साझा करने वाले देश के बिडर से खरीद पर प्रतिबंध के संबंध में भारत के साथ भूमि सीमा साझा करने वाले देश का कोई भी बिडर इस निविदा में बिड देने के लिए तभी पात्र होगा जब वह बिड देने वाला सक्षम प्राधिकारी के पास पंजीकृत हो। बिड में भाग लेते समय बिडर को इसका अनुपालन करना होगा और कोई भी गलत घोषणा किए जाने व इसका अनुपालन न करने पर अनुबंध को तत्काल समाप्त करने और कानून के अनुसार आगे की कानूनी कार्रवाई का आधार होगा।

---Thank You/धन्यवाद---

Bid Number/बोली 7मांक (बड सं?या) : GEM/2024/B/5028004

Dated/ढनांक : 08-06-2024

Repairing of 2 no.s of PVA tank

Delivery: FOR SPM, Narmadapuram within 90 days of issue of contract in GeM

Payment Terms: 100% on receipt and acceptance of goods by the consignee and on production of all required documents by the supplier.

Scope of Work

Hiring an agency for repairing of 2 no.s of PVA tank
PVA Storage Tank, 1 No.
PVA Transfer Tank, 1 No.

1. Removal of cover plate and insulation
 2. Removal of damaged ss plate.
 3. Removal of damaged copper tube (15mm*1mm)
 4. Cleaning of both Outside & Inside body of tank.
 5. Fixing of copper tube (Appx length 30 mtr for 1 tank) copper tube should be on single length to avoided joints
 6. Fixing of SS plate (size appx 3000*1500*2 mm) apx 2 plates for 1 tank
- All consumable welding electrode, gas cylinder, SS 316 plate (Thickness- 2mm), Cooper tube (Diameter-15mm, Thickness-1mm)etc are in our scope of vendor

DRG PM#5/158 (for storage tank) attached for reference purpose.

Firm may visit SPM for any technical clarification.

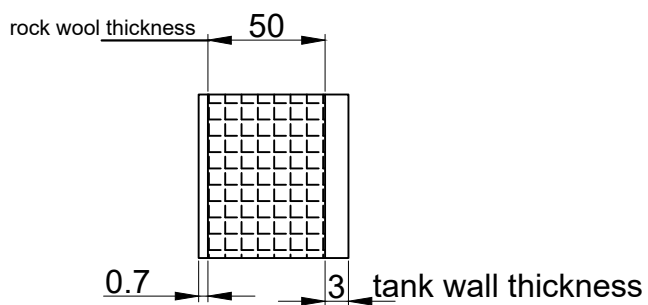
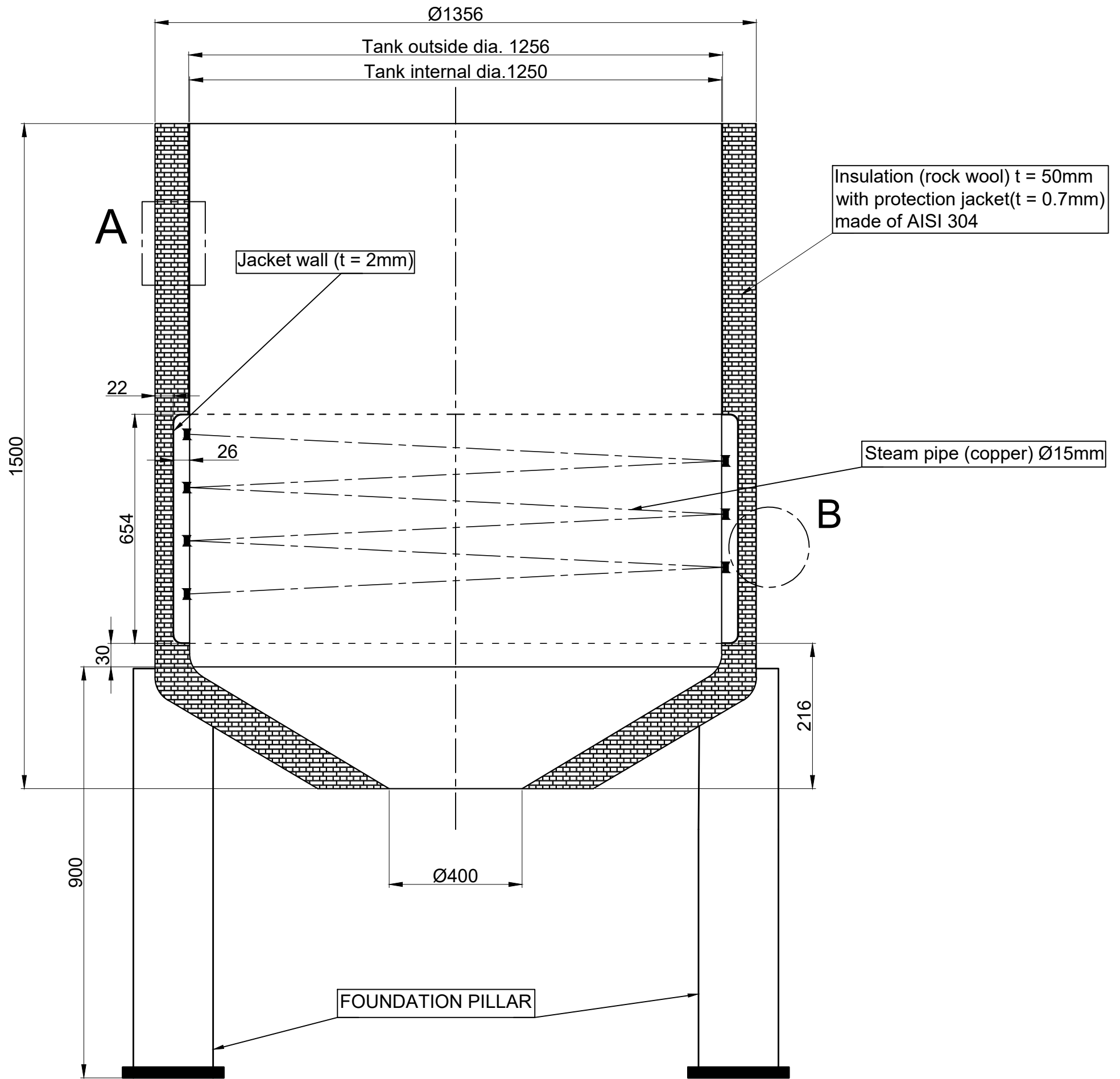

Detail of "A"

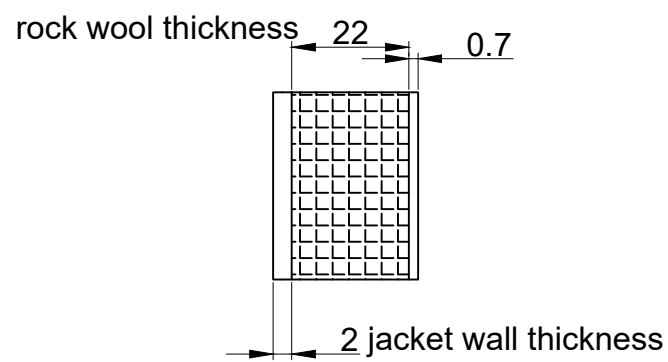

Detail of "B"

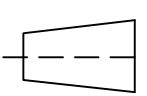
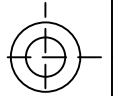
 SECURITY PAPER MILL NARMADAPURAM			
PM#5		DRG. NO.	
PVA Storage Tank		PM#5/158	
DRG. BY	N.K	SCALE - NTS	UNIT : MM
Checked		 	REV.
Approved			
DATE	23/10/2023		

Repairing of PVA Tank of SPM, Narmadapuram**Price Schedule to be submitted with Price Bid**

Sr. No.	Trip and Type of Vehicle	Qty (No.)	Rate	GST as applicable	Total
1	Repairing of PVA Storage Tank	1			
2	Repairing of PVA Transfer Tank	1			
Total					
	Method of Evaluation	The method of evaluation of L1 criteria for awarding the contract shall be decided taking into consideration the total landed price up to SPM Narmadapuram.			