



Bid Number/बोली क्रमांक (बिड संख्या):
GEM/2023/B/3959573
Dated/दिनांक : 14-09-2023

Bid Document/ बिड दस्तावेज़

Bid Details/बिड विवरण	
Bid End Date/Time/बिड बंद होने की तारीख/समय	13-10-2023 13:00:00
Bid Opening Date/Time/बिड खुलने की तारीख/समय	13-10-2023 13:30:00
Bid Offer Validity (From End Date)/बिड पेशकश वैधता (बंद होने की तारीख से)	180 (Days)
Ministry/State Name/मंत्रालय/राज्य का नाम	Ministry Of Finance
Department Name/विभाग का नाम	Department Of Economic Affairs
Organisation Name/संगठन का नाम	Security Printing And Minting Corporation Of India Limited (spmci)
Office Name/कार्यालय का नाम	Janpath
Total Quantity/कुल मात्रा	47
Item Category/मद केटेगरी	Pressure Transmitter , Level Transmitter , Press TransOnCPress Sens , Press TransOnc Press Sens , Fixed Pressure Transmitter , Level Tran , Level Transmitter for Master Vat , Level Transmitter for Master Sizer , Radar Level tx Non Contract
BOQ Title/बीओक्यू शीर्षक	level tramitter and pressure transmitter
Minimum Average Annual Turnover of the bidder (For 3 Years)/बिडर का न्यूनतम औसत वार्षिक टर्नओवर (3 वर्षों का)	24 Lakh (s)
OEM Average Turnover (Last 3 Years)/मूल उपकरण निर्माता का औसत टर्नओवर (गत 3 वर्षों का)	24 Lakh (s)
Years of Past Experience Required for same/similar service/उन्हीं/समान सेवाओं के लिए अपेक्षित विगत अनुभव के वर्ष	3 Year (s)
MSE Exemption for Years Of Experience/अनुभव के वर्षों से एमएसई छूट/ and Turnover/टर्नओवर के लिए एमएसई को छूट प्राप्त है	Yes
Startup Exemption for Years Of Experience/अनुभव के वर्षों से स्टार्टअप छूट/ and Turnover/ टर्नओवर के लिए स्टार्टअप को छूट प्राप्त है	Yes

Bid Details/बिड विवरण	
Document required from seller/विक्रेता से मांगे गए दस्तावेज़	Experience Criteria,Bidder Turnover,Certificate (Requested in ATC),OEM Authorization Certificate,OEM Annual Turnover,Additional Doc 1 (Requested in ATC),Compliance of BoQ specification and supporting document *In case any bidder is seeking exemption from Experience / Turnover Criteria, the supporting documents to prove his eligibility for exemption must be uploaded for evaluation by the buyer
Bid to RA enabled/बिड से रिवर्स नीलामी सक्रिय किया	No
Type of Bid/बिड का प्रकार	Two Packet Bid
Primary product category	Pressure Transmitter
Time allowed for Technical Clarifications during technical evaluation/तकनीकी मूल्यांकन के दौरान तकनीकी स्पष्टीकरण हेतु अनुमत समय	2 Days
Inspection Required (By Empanelled Inspection Authority / Agencies pre-registered with GeM)	No
Evaluation Method/मूल्यांकन पद्धति	Total value wise evaluation

EMD Detail/ईएमडी विवरण

Advisory Bank/एडवाइजरी बैंक	Indusind bank
EMD Amount/ईएमडी राशि	120000

ePBG Detail/ईपीबीजी विवरण

Advisory Bank/एडवाइजरी बैंक	Indusind bank
ePBG Percentage(%) /ईपीबीजी प्रतिशत (%)	10.00
Duration of ePBG required (Months)/ईपीबीजी की अपेक्षित अवधि (महीने).	14

(a). EMD EXEMPTION: The bidder seeking EMD exemption, must submit the valid supporting document for the relevant category as per GeM GTC with the bid. Under MSE category, only manufacturers for goods and Service Providers for Services are eligible for exemption from EMD. Traders are excluded from the purview of this Policy./जेम की शर्तों के अनुसार ईएमडी छूट के इच्छुक बिडर को संबंधित केटेगरी के लिए बिड के साथ वैध समर्थित दस्तावेज़ प्रस्तुत करने हैं। एमएसई केटेगरी के अंतर्गत केवल वस्तुओं के लिए विनिर्माता तथा सेवाओं के लिए सेवा प्रदाता ईएमडी से छूट के पात्र हैं। व्यापारियों को इस नीति के दायरे से बाहर रखा गया है।

(b). EMD & Performance security should be in favour of Beneficiary, wherever it is applicable./ईएमडी और संपादन जमानत राशि, जहां यह लागू होती है, लाभार्थी के पक्ष में होनी चाहिए।

Beneficiary/लाभार्थी :

security paper mill
security paper mill

(Security Paper Mill)

Splitting/विभाजन

Bid splitting not applied/बोली विभाजन लागू नहीं किया गया.

MII Purchase Preference/एमआईआई खरीद वरीयता

MII Purchase Preference/एमआईआई खरीद वरीयता	Yes
--	-----

MSE Purchase Preference/एमएसई खरीद वरीयता

MSE Purchase Preference/एमएसई खरीद वरीयता	Yes
---	-----

1. If the bidder is a Micro or Small Enterprise as per latest definitions under MSME rules, the bidder shall be exempted from the requirement of "Bidder Turnover" criteria and "Experience Criteria" subject to meeting of quality and technical specifications. If the bidder is OEM of the offered products, it would be exempted from the "OEM Average Turnover" criteria also subject to meeting of quality and technical specifications. In case any bidder is seeking exemption from Turnover / Experience Criteria, the supporting documents to prove his eligibility for exemption must be uploaded for evaluation by the buyer.
2. If the bidder is a Startup, the bidder shall be exempted from the requirement of "Bidder Turnover" criteria and "Experience Criteria" subject to their meeting of quality and technical specifications. If the bidder is OEM of the offered products, it would be exempted from the "OEM Average Turnover" criteria also subject to meeting of quality and technical specifications. In case any bidder is seeking exemption from Turnover / Experience Criteria, the supporting documents to prove his eligibility for exemption must be uploaded for evaluation by the buyer.
3. The minimum average annual financial turnover of the bidder during the last three years, ending on 31st March of the previous financial year, should be as indicated above in the bid document. Documentary evidence in the form of certified Audited Balance Sheets of relevant periods or a certificate from the Chartered Accountant / Cost Accountant indicating the turnover details for the relevant period shall be uploaded with the bid. In case the date of constitution / incorporation of the bidder is less than 3-year-old, the average turnover in respect of the completed financial years after the date of constitution shall be taken into account for this criteria.
4. Experience Criteria: In respect of the filter applied for experience criteria, the Bidder or its OEM {themselves or through reseller(s)} should have regularly, manufactured and supplied same or similar Category Products to any Central / State Govt Organization / PSU / Public Listed Company for number of Financial years as indicated above in the bid document before the bid opening date. Copies of relevant contracts to be submitted along with bid in support of having supplied some quantity during each of the Financial year. In case of bunch bids, the category of primary product having highest value should meet this criterion.
5. OEM Turn Over Criteria: The minimum average annual financial turnover of the OEM of the offered product during the last three years, ending on 31st March of the previous financial year, should be as indicated in the bid document. Documentary evidence in the form of certified Audited Balance Sheets of relevant periods or a certificate from the Chartered Accountant / Cost Accountant indicating the turnover details for the relevant period shall be uploaded with the bid. In case the date of constitution / incorporation of the OEM is less than 3 year old, the average turnover in respect of the completed financial years after the date of constitution shall be taken into account for this criteria.
6. Preference to Make In India products (For bids < 200 Crore): Preference shall be given to Class 1 local supplier as defined in public procurement (Preference to Make in India), Order 2017 as amended from time to time and its subsequent Orders/Notifications issued by concerned Nodal Ministry for specific Goods/Products. The minimum local content to qualify as a Class 1 local supplier is denoted in the bid document. If the bidder wants to avail the Purchase preference, the bidder must upload a certificate from the OEM regarding the percentage of the local content and the details of locations at which the local value addition is made along with their bid, failing which no purchase preference shall be granted. In case the bid value is more than Rs 10 Crore, the declaration relating to percentage of local content shall be certified by the statutory auditor or cost auditor, if the OEM is a company and by a practicing cost accountant or a chartered accountant for OEMs other than companies as per the Public Procurement (preference to Make-in -India) order 2017 dated 04.06.2020. Only Class-I and Class-II Local suppliers as per MII order dated 4.6.2020 will be eligible to bid. Non - Local suppliers as per MII order dated 04.06.2020 are

not eligible to participate. However, eligible micro and small enterprises will be allowed to participate .The buyers are advised to refer the OM No.F.1/4/2021-PPD dated 18.05.2023.

[OM No.1 4 2021 PPD dated 18.05.2023](#) for compliance of Concurrent application of Public Procurement Policy for Micro and Small Enterprises Order, 2012 and Public Procurement (Preference to Make in India) Order, 2017.

7. Purchase preference to Micro and Small Enterprises (MSEs): Purchase preference will be given to MSEs as defined in Public Procurement Policy for Micro and Small Enterprises (MSEs) Order, 2012 dated 23.03.2012 issued by Ministry of Micro, Small and Medium Enterprises and its subsequent Orders/Notifications issued by concerned Ministry. If the bidder wants to avail the Purchase preference, the bidder must be the manufacturer of the offered product in case of bid for supply of goods. Traders are excluded from the purview of Public Procurement Policy for Micro and Small Enterprises. In respect of bid for Services, the bidder must be the Service provider of the offered Service. Relevant documentary evidence in this regard shall be uploaded along with the bid in respect of the offered product or service. If L-1 is not an MSE and MSE Seller (s) has/have quoted price within L-1+ 15% (Selected by Buyer)of margin of purchase preference /price band defined in relevant policy, such Seller shall be given opportunity to match L-1 price and contract will be awarded for 25%(selected by Buyer) percentage of total QUANTITY.The buyers are advised to refer the OM No.F.1/4/2021-PPD dated 18.05.2023

[OM No.1 4 2021 PPD dated 18.05.2023](#) for compliance of Concurrent application of Public Procurement Policy for Micro and Small Enterprises Order, 2012 and Public Procurement (Preference to Make in India) Order, 2017.

8. Estimated Bid Value indicated above is being declared solely for the purpose of guidance on EMD amount and for determining the Eligibility Criteria related to Turn Over, Past Performance and Project / Past Experience etc. This has no relevance or bearing on the price to be quoted by the bidders and is also not going to have any impact on bid participation. Also this is not going to be used as a criteria in determining reasonableness of quoted prices which would be determined by the buyer based on its own assessment of reasonableness and based on competitive prices received in Bid / RA process.

Pressure Transmitter

(Minimum 50% and 20% Local Content required for qualifying as Class 1 and Class 2 Local Supplier respectively/क्रमशः श्रेणी 1 और श्रेणी 2 के स्थानीय आपूर्तिकर्ता के रूप में अर्हता प्राप्त करने के लिए आवश्यक)

Technical Specifications/तकनीकी विशिष्टियाँ

Specification Document	View File
BOQ Detail Document	View File

Advisory-Please refer attached BOQ document for detailed consignee list and delivery period.

Consignees/Reporting Officer/परेषिती/रिपोर्टिंग अधिकारी and/ तथा Quantity/मात्रा

S.No./क्र. सं.	Consignee Reporting/Officer/ परेषिती/रिपोर्टिंग अधिकारी	Address/पता	Quantity/मात्रा	Delivery Days/डिलीवरी के दिन
1	Vikas Kumar	461005,Security Paper Mill ,Narmadapuram , Madhya Pradesh	8	120

Pressure Transmitter

(Minimum 50% and 20% Local Content required for qualifying as Class 1 and Class 2 Local Supplier respectively/क्रमशः श्रेणी 1 और श्रेणी 2 के स्थानीय आपूर्तिकर्ता के रूप में अर्हता प्राप्त करने के लिए आवश्यक)

Technical Specifications/तकनीकी विशिष्टियाँ

Specification Document	View File
BOQ Detail Document	View File

Advisory-Please refer attached BOQ document for detailed consignee list and delivery period.

Consignees/Reporting Officer/परेषिती/रिपोर्टिंग अधिकारी and/ तथा Quantity/मात्रा

S.No./क्र. सं.	Consignee Reporting/Officer/ परेषिती/रिपोर्टिंग अधिकारी	Address/पता	Quantity/मात्रा	Delivery Days/डिलीवरी के दिन
1	Vikas Kumar	461005,Security Paper Mill ,Narmadapuram , Madhya Pradesh	4	120

Level Transmitter

(Minimum 50% and 20% Local Content required for qualifying as Class 1 and Class 2 Local Supplier respectively/क्रमशः श्रेणी 1 और श्रेणी 2 के स्थानीय आपूर्तिकर्ता के रूप में अर्हता प्राप्त करने के लिए आवश्यक)

Technical Specifications/तकनीकी विशिष्टियाँ

Specification Document	View File
BOQ Detail Document	View File

Advisory-Please refer attached BOQ document for detailed consignee list and delivery period.

Consignees/Reporting Officer/परेषिती/रिपोर्टिंग अधिकारी and/ तथा Quantity/मात्रा

S.No./क्र. सं.	Consignee Reporting/Officer/ परेषिती/रिपोर्टिंग अधिकारी	Address/पता	Quantity/मात्रा	Delivery Days/डिलीवरी के दिन
1	Vikas Kumar	461005,Security Paper Mill ,Narmadapuram , Madhya Pradesh	10	120

Press TransOnCPress Sens

(Minimum 50% and 20% Local Content required for qualifying as Class 1 and Class 2 Local Supplier respectively/क्रमशः श्रेणी 1 और श्रेणी 2 के स्थानीय आपूर्तिकर्ता के रूप में अर्हता प्राप्त करने के लिए आवश्यक)

Technical Specifications/तकनीकी विशिष्टियाँ

Specification Document	View File
BOQ Detail Document	View File

Advisory-Please refer attached BOQ document for detailed consignee list and delivery period.

Consignees/Reporting Officer/परेषिती/रिपोर्टिंग अधिकारी and/ तथा Quantity/मात्रा

S.No./क्र. सं.	Consignee Reporting/Officer/ परेषिती/रिपोर्टिंग अधिकारी	Address/पता	Quantity/मात्रा	Delivery Days/डिलीवरी के दिन
1	Vikas Kumar	461005,Security Paper Mill ,Narmadapuram , Madhya Pradesh	8	120

Press TransOnc Press Sens

(Minimum 50% and 20% Local Content required for qualifying as Class 1 and Class 2 Local Supplier respectively/क्रमशः श्रेणी 1 और श्रेणी 2 के स्थानीय आपूर्तिकर्ता के रूप में अर्हता प्राप्त करने के लिए आवश्यक)

Technical Specifications/तकनीकी विशिष्टियाँ

Specification Document	View File
BOQ Detail Document	View File

Advisory-Please refer attached BOQ document for detailed consignee list and delivery period.

Consignees/Reporting Officer/परेषिती/रिपोर्टिंग अधिकारी and/ तथा Quantity/मात्र

S.No./क्र. सं.	Consignee Reporting/Officer/ परेषिती/रिपोर्टिंग अधिकारी	Address/पता	Quantity/मात्र	Delivery Days/डिलीवरी के दिन
1	Vikas Kumar	461005,Security Paper Mill ,Narmadapuram , Madhya Pradesh	5	120

Fixed Pressure Transmitter

(Minimum 50% and 20% Local Content required for qualifying as Class 1 and Class 2 Local Supplier respectively/क्रमशः श्रेणी 1 और श्रेणी 2 के स्थानीय आपूर्तिकर्ता के रूप में अर्हता प्राप्त करने के लिए आवश्यक)

Technical Specifications/तकनीकी विशिष्टियाँ

Specification Document	View File
BOQ Detail Document	View File

Advisory-Please refer attached BOQ document for detailed consignee list and delivery period.

Consignees/Reporting Officer/परेषिती/रिपोर्टिंग अधिकारी and/ तथा Quantity/मात्र

S.No./क्र. सं.	Consignee Reporting/Officer/ परेषिती/रिपोर्टिंग अधिकारी	Address/पता	Quantity/मात्र	Delivery Days/डिलीवरी के दिन
1	Vikas Kumar	461005,Security Paper Mill ,Narmadapuram , Madhya Pradesh	2	120

Fixed Pressure Transmitter

(Minimum 50% and 20% Local Content required for qualifying as Class 1 and Class 2 Local Supplier respectively/क्रमशः श्रेणी 1 और श्रेणी 2 के स्थानीय आपूर्तिकर्ता के रूप में अर्हता प्राप्त करने के लिए आवश्यक)

Technical Specifications/तकनीकी विशिष्टियाँ

Specification Document	View File
BOQ Detail Document	View File

Advisory-Please refer attached BOQ document for detailed consignee list and delivery period.

Consignees/Reporting Officer/परेषिती/रिपोर्टिंग अधिकारी and/ तथा Quantity/मात्र

S.No./क्र. सं.	Consignee Reporting/Officer/ परेषिती/रिपोर्टिंग अधिकारी	Address/पता	Quantity/मात्र	Delivery Days/डिलीवरी के दिन
1	Vikas Kumar	461005,Security Paper Mill ,Narmadapuram , Madhya Pradesh	2	120

Level Tran

(Minimum 50% and 20% Local Content required for qualifying as Class 1 and Class 2 Local Supplier respectively/क्रमशः श्रेणी 1 और श्रेणी 2 के स्थानीय आपूर्तिकर्ता के रूप में अर्हता प्राप्त करने के लिए आवश्यक)

Technical Specifications/तकनीकी विशिष्टियाँ

Specification Document	View File
BOQ Detail Document	View File

Advisory-Please refer attached BOQ document for detailed consignee list and delivery period.

Consignees/Reporting Officer/परेषिती/रिपोर्टिंग अधिकारी and/ तथा Quantity/मात्र

S.No./क्र. सं.	Consignee Reporting/Officer/ परेषिती/रिपोर्टिंग अधिकारी	Address/पता	Quantity/मात्रा	Delivery Days/डिलीवरी के दिन
1	Vikas Kumar	461005,Security Paper Mill ,Narmadapuram , Madhya Pradesh	3	120

Level Transmitter For Master Vat

(Minimum 50% and 20% Local Content required for qualifying as Class 1 and Class 2 Local Supplier respectively/क्रमशः श्रेणी 1 और श्रेणी 2 के स्थानीय आपूर्तिकर्ता के रूप में अर्हता प्राप्त करने के लिए आवश्यक)

Technical Specifications/तकनीकी विशिष्टियाँ

Specification Document	View File
BOQ Detail Document	View File

Advisory-Please refer attached BOQ document for detailed consignee list and delivery period.

Consignees/Reporting Officer/परेषिती/रिपोर्टिंग अधिकारी and/ तथा Quantity/मात्रा

S.No./क्र. सं.	Consignee Reporting/Officer/ परेषिती/रिपोर्टिंग अधिकारी	Address/पता	Quantity/मात्रा	Delivery Days/डिलीवरी के दिन
1	Vikas Kumar	461005,Security Paper Mill ,Narmadapuram , Madhya Pradesh	1	120

Level Transmitter For Master Sizer

(Minimum 50% and 20% Local Content required for qualifying as Class 1 and Class 2 Local Supplier respectively/क्रमशः श्रेणी 1 और श्रेणी 2 के स्थानीय आपूर्तिकर्ता के रूप में अर्हता प्राप्त करने के लिए आवश्यक)

Technical Specifications/तकनीकी विशिष्टियाँ

Specification Document	View File
BOQ Detail Document	View File

Advisory-Please refer attached BOQ document for detailed consignee list and delivery period.

Consignees/Reporting Officer/परेषिती/रिपोर्टिंग अधिकारी and/ तथा Quantity/मात्र

S.No./क्र. सं.	Consignee Reporting/Officer/ परेषिती/रिपोर्टिंग अधिकारी	Address/पता	Quantity/मात्र	Delivery Days/डिलीवरी के दिन
1	Vikas Kumar	461005,Security Paper Mill ,Narmadapuram , Madhya Pradesh	1	120

Radar Level Tx Non Contract

(Minimum 50% and 20% Local Content required for qualifying as Class 1 and Class 2 Local Supplier respectively/क्रमशः श्रेणी 1 और श्रेणी 2 के स्थानीय आपूर्तिकर्ता के रूप में अर्हता प्राप्त करने के लिए आवश्यक)

Technical Specifications/तकनीकी विशिष्टियाँ

Specification Document	View File
BOQ Detail Document	View File

Advisory-Please refer attached BOQ document for detailed consignee list and delivery period.

Consignees/Reporting Officer/परेषिती/रिपोर्टिंग अधिकारी and/ तथा Quantity/मात्र

S.No./क्र. सं.	Consignee Reporting/Officer/ परेषिती/रिपोर्टिंग अधिकारी	Address/पता	Quantity/मात्र	Delivery Days/डिलीवरी के दिन
1	Vikas Kumar	461005,Security Paper Mill ,Narmadapuram , Madhya Pradesh	3	120

Buyer Added Bid Specific Terms and Conditions/क्रेता द्वारा जोड़ी गई बिड की विशेष शर्तें

1. **Generic**

OPTION CLAUSE: The Purchaser reserves the right to increase or decrease the quantity to be ordered up to 25 percent of bid quantity at the time of placement of contract. The purchaser also reserves the right to increase the ordered quantity by up to 25% of the contracted quantity during the currency of the contract at the contracted rates. Bidders are bound to accept the orders accordingly.

2. **Turnover**

Bidder Turn Over Criteria: The minimum average annual financial turnover of the bidder during the last three years, ending on 31st March of the previous financial year, should be as indicated in the bid document. Documentary evidence in the form of certified Audited Balance Sheets of relevant periods or a certificate from the Chartered Accountant / Cost Accountant indicating the turnover details for the relevant period shall be uploaded with the bid. In case the date of constitution / incorporation of the bidder is less than 3 year old, the average turnover in respect of the completed financial years after the date of constitution shall be taken into account for this criteria.

3. **Forms of EMD and PBG**

Bidders can also submit the EMD with Account Payee Demand Draft in favour of

security paper mill
payable at
narmadapuram

Bidder has to upload scanned copy / proof of the DD along with bid and has to ensure delivery of hardcopy to the Buyer within 5 days of Bid End date / Bid Opening date.

4. **Forms of EMD and PBG**

Bidders can also submit the EMD with Fixed Deposit Receipt made out or pledged in the name of A/C (Name of the Buyer). The bank should certify on it that the deposit can be withdrawn only on the demand or with the sanction of the pledgee. For release of EMD, the FDR will be released in the favour of the bidder by the Buyer after making endorsement on the back of the FDR duly signed and stamped along with covering letter. Bidder has to upload scanned copy/ proof of the FDR along with bid and has to ensure delivery of hardcopy to the Buyer within 5 days of Bid End date/ Bid Opening date

5. **Generic**

Bidders are advised to check applicable GST on their own before quoting. Buyer will not take any responsibility in this regards. GST reimbursement will be as per actuals or as per applicable rates (whichever is lower), subject to the maximum of quoted GST %.

6. **Buyer Added Bid Specific ATC**

Buyer Added text based ATC clauses

If required SPM may visit the factory during any stage, to ascertain the bidder manufacturing capability & quality control methodology.

Firm should submit the following:-

Firm should submit the following information regarding the capacity and performance:-

- a) Name of the machine utilized to supply the quoted product.
- b) The number of machines being utilized for the production and the capacity of each machine.
- c) Supply orders in hand and proportionate capacity to supply quoted amount.

viii. Firm shall submit the declaration on letter head duly seal & signed by competent authority stating, "We have not been blacklisted/debarred by BNPMIPL/BRBNMPL/SPMCIL or any Govt. Departments for participation in tenders as on the date of opening of tender. The information provided above is correct and true

to the best of my knowledge and belief.”

7. **Buyer Added Bid Specific ATC**

Buyer uploaded ATC document [Click here to view the file.](#)

8. **Warranty**

Warranty period of the supplied products shall be 1 years from the date of final acceptance of goods or after completion of installation, commissioning & testing of goods (if included in the scope of supply), at consignee location. OEM Warranty certificates must be submitted by Successful Bidder at the time of delivery of Goods. The seller should guarantee the rectification of goods in case of any break down during the guarantee period. Seller should have well established Installation, Commissioning, Training, Troubleshooting and Maintenance Service group in INDIA for attending the after sales service. Details of Service Centres near consignee destinations are to be uploaded along with the bid.

9. **Generic**

Experience Criteria: The Bidder or its OEM {themselves or through reseller(s)} should have regularly, manufactured and supplied same or similar Category Products to any Central / State Govt Organization / PSU / Public Listed Company for 3 years before the bid opening date. Copies of relevant contracts to be submitted along with bid in support of having supplied some quantity during each of the year. In case of bunch bids, the primary product having highest value should meet this criterion.

10. **Generic**

Manufacturer Authorization:Wherever Authorised Distributors/service providers are submitting the bid, Authorisation Form /Certificate with OEM/Original Service Provider details such as name, designation, address, e-mail Id and Phone No. required to be furnished along with the bid

11. **Turnover**

OEM Turn Over Criteria: The minimum average annual financial turnover of the OEM of the offered product during the last three years, ending on 31st March of the previous financial year, should be as indicated in the bid document. Documentary evidence in the form of certified Audited Balance Sheets of relevant periods or a certificate from the Chartered Accountant / Cost Accountant indicating the turnover details for the relevant period shall be uploaded with the bid. In case the date of constitution / incorporation of the OEM is less than 3 year old, the average turnover in respect of the completed financial years after the date of constitution shall be taken into account for this criteria. In case of bunch bids, the OEM of CATEGORY RELATED TO primary product having highest bid value should meet this criterion.

12. **Past Project Experience**

Proof for Past Experience and Project Experience clause: For fulfilling the experience criteria any one of the following documents may be considered as valid proof for meeting the experience criteria:a. Contract copy along with Invoice(s) with self-certification by the bidder that service/supplies against the invoices have been executed.b. Execution certificate by client with contract value.c. Any other document in support of contract execution like Third Party Inspection release note, etc.**Proof for Past Experience and Project Experience clause:** For fulfilling the experience criteria any one of the following documents may be considered as valid proof for meeting the experience criteria:a. Contract copy along with Invoice(s) with self-certification by the bidder that service/supplies against the invoices have been executed.b. Execution certificate by client with contract value.c. Any other document in support of contract execution like Third Party Inspection release note, etc.

13. **Forms of EMD and PBG**

Successful Bidder can submit the Performance Security in the form of Account Payee Demand Draft also (besides PBG which is allowed as per GeM GTC). DD should be made in favour of

security paper mill
payable at
narmadapuram

. After award of contract, Successful Bidder can upload scanned copy of the DD in place of PBG and has to ensure delivery of hard copy to the original DD to the Buyer within 15 days of award of contract.

14. **Forms of EMD and PBG**

Successful Bidder can submit the Performance Security in the form of Fixed Deposit Receipt also (besides PBG which is allowed as per GeM GTC). FDR should be made out or pledged in the name of

security paper mill

A/C (Name of the Seller). The bank should certify on it that the deposit can be withdrawn only on the demand or with the sanction of the pledgee. For release of Security Deposit, the FDR will be released in favour of bidder by the Buyer after making endorsement on the back of the FDR duly signed and stamped along with covering letter. Successful Bidder has to upload scanned copy of the FDR document in place of PBG and has to ensure delivery of hard copy of Original FDR to the Buyer within 15 days of award of contract.

Disclaimer/अस्वीकरण

The additional terms and conditions have been incorporated by the Buyer after approval of the Competent Authority in Buyer Organization, whereby Buyer organization is solely responsible for the impact of these clauses on the bidding process, its outcome, and consequences thereof including any eccentricity / restriction arising in the bidding process due to these ATCs and due to modification of technical specifications and / or terms and conditions governing the bid. Any clause(s) incorporated by the Buyer regarding following shall be treated as null and void and would not be considered as part of bid:-

1. Definition of Class I and Class II suppliers in the bid not in line with the extant Order / Office Memorandum issued by DPIIT in this regard.
2. Seeking EMD submission from bidder(s), including via Additional Terms & Conditions, in contravention to exemption provided to such sellers under GeM GTC.
3. Publishing Custom / BOQ bids for items for which regular GeM categories are available without any Category item bunched with it.
4. Creating BoQ bid for single item.
5. Mentioning specific Brand or Make or Model or Manufacturer or Dealer name.
6. Mandating submission of documents in physical form as a pre-requisite to qualify bidders.
7. Floating / creation of work contracts as Custom Bids in Services.
8. Seeking sample with bid or approval of samples during bid evaluation process.
9. Mandating foreign / international certifications even in case of existence of Indian Standards without specifying equivalent Indian Certification / standards.
10. Seeking experience from specific organization / department / institute only or from foreign / export experience.
11. Creating bid for items from irrelevant categories.
12. Incorporating any clause against the MSME policy and Preference to Make in India Policy.
13. Reference of conditions published on any external site or reference to external documents/clauses.
14. Asking for any Tender fee / Bid Participation fee / Auction fee in case of Bids / Forward Auction, as the case may be.

Further, if any seller has any objection/grievance against these additional clauses or otherwise on any aspect of this bid, they can raise their representation against the same by using the Representation window provided in the bid details field in Seller dashboard after logging in as a seller within 4 days of bid publication on GeM. Buyer is duty bound to reply to all such representations and would not be allowed to open bids if he fails to reply to such representations.

[This Bid is also governed by the General Terms and Conditions/ यह बिड सामान्य शर्तों के अंतर्गत भी शासित है](#)

In terms of GeM GTC clause 26 regarding Restrictions on procurement from a bidder of a country which shares a land border with India, any bidder from a country which shares a land border with India will be eligible to bid in this tender only if the bidder is registered with the Competent Authority. While participating in bid, Bidder has to undertake compliance of this and any false declaration and non-compliance of this would be a ground for immediate termination of the contract and further legal action in accordance with the laws./जेम की सामान्य शर्तों के खंड 26 के संदर्भ में भारत के साथ भूमि सीमा साझा करने वाले देश के बिडर से खरीद पर प्रतिबंध के संबंध में भारत के साथ भूमि सीमा साझा करने वाले देश का कोई भी बिडर इस निविदा में बिड देने के लिए तभी पात्र होगा जब वह बिड देने वाला सक्षम प्राधिकारी के पास पंजीकृत हो।बिड में भाग लेते समय बिडर को इसका अनुपालन करना होगा और कोई भी गलत घोषणा किए जाने व इसका अनुपालन न करने पर अनुबंध को तत्काल समाप्त करने और कानून के अनुसार आगे की कानूनी कार्रवाई का आधार होगा।

---Thank You/धन्यवाद---

Item of Requisition	Short Text	Technical Details	Qty	Unit of Measure
10	Pressure Transmitter G1/2 A 1.5 bar	<p>Item No. 10</p> <p>Technical specification: Pressure Transmitter G1/2 A 1.5 bar Pressure Transmitter -1 to 1.5 Bar 1. Process fitting / Material : Thread G½, EN837; manometer connection / 316L 2. Sealing concept : Double seal 3. Measuring cell seal / Process temperature : FKM (VP2/A) / - - 20..+130°C 4. Measuring range :- - 1...+1.5bar (- 100...+150kPa) 5. Accuracy class : 0.20% 6. Input supply 10 to 24 VDC 7. Electronics : Electronics : Two-wire 4 ... 20mA DC with digital communication (HART Protocol) 8. Optional overvoltage protection : Without 9. Housing: Aluminum single chamber 10. Housing version / Protection : compact / IP66/IP67; NEMA 4X 11. Cable entry / Connection: M20x1.5 / Cable gland PA black (ø5-9mm), standard 12. Display/adjustment module PLICSCOM: Mounted 13. Measuring cell type : CERTEC - ceramic measuring cell 14. Electronic differential pressure : Suitable configuration 15. Attached process seal : Klingersil C-4400 16. process pressure : -1 bar to 27 bar 17. Process medium: pulp/water/steam</p> <p>All dimensions shall be as per attached Drawing. All dimensions are in mm.</p>	8	EA

20	Pressure Transmitter G1/2 A 10 bar	<p>Item No. 20</p> <p>Technical specification: Pressure Transmitter G1/2 A 10 bar Pressure Transmitter -1 to 10 Bar 1.Process fitting / Material : Thread G½, EN837; manometer connection / 316L 2.Sealing concept : Double seal 3. Measuring cell seal / Process temperature : FKM (VP2/A) / -20...+130°C 4.Measuring range : 1...+10 bar (-100...+1000kPa) 5.Accuracy class : 0.20% 6.Input supply 10 - 24 Vdc 7.Electronics : Two-wire 4 ... 20mA DC with digital communication (HART Protocol) 8.Optional overvoltage protection : Without 9.Housing: Aluminum single chamber 10.Housing version / Protection : compact / IP66/IP67; NEMA 4X 11.Cable entry / Connection: M20x1.5 / Cable gland PA black (ø5-9mm), standard 12.Display/adjustment module PLICSCOM: Mounted 13.Measuring cell type : CERTEC - ceramic measuring cell 14.Electronic differential pressure : Suitable configuration 15.Attached process seal : Klingersil C-4400 16.process pressure : -1 bar to 60 bar 17. Process medium: pulp/water/steam</p> <p style="text-align: center;">All dimensions shall be as per attached Drawing. All dimensions are in mm</p>	4	EA
----	------------------------------------	--	---	----

30	Level transmitter M30X1.5 1 bar	<p>Item No. 30</p> <p>Technical specification: Level transmitter M30X1.5 1 bar Level transmitter 0 to 1 Bar 1.Process fitting / Material : Thread M30x1.5 DIN13; absolutely front-flush /316L 2.Sealing concept : Double seal 3. Measuring cell seal / Process temperature : FFKM (Perlast G75S) / - 15...+130°C 4.Measuring range : 0...+1.0bar (0...+100kPa) 5Accuracy class : 0.20% 6.Input supply 10 to 24 VDC 7.Electronics : Two-wire 4 ... 20mA DC with digital communication (HART Protocol) 8.Optional overvoltage protection : Without 9.Housing: Aluminum single chamber 10.Housing version / Protection : compact / IP66/IP67; NEMA 4X 11.Cable entry / Connection: M20x1.5 / Cable gland PA black (ø5-9mm), standard 12.Display/adjustment module PLICSCOM: Mounted 13.Measuring cell type : MINI-CERTEC - ceramic measuring cell 14.Electronic differential pressure : Suitable configuration 15.Attached process seal : FFKM Perlast G75S/G74S 16.process pressure : -1 bar to 23 bar 17. Process medium: Suitable for Pulp and water</p> <p>All dimensions shall be as per attached Drawing. All dimensions are in mm.</p>	10	EA
----	------------------------------------	--	----	----

40	PressTransOnCPressSens 154-0-500kPa	<p>Item No. 40</p> <p>Technical specification: PressTransOnCPressSens154-0-500kPa Level transmitter 0 to 5 Bar</p> <ol style="list-style-type: none"> 1.Process fitting / Material : Thread M30x1.5 DIN13; absolutely front-flush /316L 2.Sealing concept : Double seal 3. Measuring cell seal / Process temperature : FFKM (Perlast G75S) / -15...+130°C 4.Measuring range : 0...+5.0 bar (0...+500kPa) 5.Accuracy class : 0.20% 6.Input supply 10 to 24 VDC 7.Electronics : Two-wire 4 ... 20mA DC with digital communication (HART Protocol) 8.Optional overvoltage protection : Without 9.Housing: Aluminum single chamber 10.Housing version / Protection : compact / IP66/IP67; NEMA 4X 11.Display/adjustment module PLICSCOM: Mounted 12.Measuring cell type : MINI-CERTEC - ceramic measuring cell 13.Electronic differential pressure : Suitable configuration 14.Attached process seal : FFKM Perlast G75S/G74S 15.process pressure : -1 bar to 43 bar 16. Process medium: Suitable for Pulp and water <p style="text-align: center;">All dimensions shall be as per attached Drawing. All dimensions are in mm.</p>	8	EA
----	--	--	---	----

50	PressTransOnCPressSens 154-0-1000kPa	<p>Item No. 50</p> <p>Technical specification: PressTransOnCPressSens154-0-1000kPa Pressure transmitter 0 to 10 Bar Range: 0 to 10 Bar</p> <ol style="list-style-type: none"> 1.Process fitting / Material : Thread M30x1.5 DIN13; absolutely front-flush /316L 2.Sealing concept : Double seal 3. Measuring cell seal / Process temperature : FFKM (Perlast G75S) / -15...+130°C 4.Measuring range : 0...+10 bar (0...+1000kPa) 5.Accuracy class : 0.20% 6.Input supply 10 to 24 VDC 7.Electronics : Two-wire 4 ... 20mA DC with digital communication (HART Protocol) 8.Optional overvoltage protection : Without 9.Housing: Aluminum single chamber 10.Housing version / Protection : compact / IP66/IP67; NEMA 4X 11.Display/adjustment module PLICSCOM: Mounted 12.Measuring cell type : MINI-CERTEC - ceramic measuring cell 13.Electronic differential pressure : Suitable configuration 14.Attached process seal : FFKM Perlast G75S/G74S 15.process pressure : -1 bar to 60 bar 16. Process medium: Suitable for Pulp and water <p style="text-align: center;">All dimensions(mm) shall be as per attached Drawing.</p>	5	EA
----	---	--	---	----

60	Fixed pressure transmitter G1B 40 kPa	<p>Item No. 60 Technical specification: Fixed pressure transmitter G1B 40 kPa Fixed Pressure Transmitter 0 to 0.4 Bar</p> <ol style="list-style-type: none"> 1. Process fitting / Material : Thread G1B, front flush / 316 Ti with O-ring, up to 1.6Bar/ NBR 2. Measuring range : 0...+0.4 bar (0...+40kPa) 3. Accuracy class : 0.20% 4. Electronics : Two-wire 4 ... 20 mA 5. Measuring cell type : Piezoresistive - metallic measuring cell 6. process pressure : -1 bar to 3.0 bar 7. 360° status display :with 8. Electrical connection/ protection : 4-pole plug connection ISO4400 M16 / IP65 9. Media: Gases, Vapours and liquids, also viscous products 10. Auxiliary Energy: 10...30 VDC 11. Connection Type: Thread Male 12. Operating Temperature: 20...80 °C 	2	EA
70	Fixed pressure transmitter G1/2B 25 bar	<p>Item No.70 Technical specification: Fixed pressure transmitter G1/2B 25 bar Fixed Pressure Transmitter 0 to 25 Bar</p> <ol style="list-style-type: none"> 1.Process fitting / Material : Thread G1/2B, manometer connection/ 316 Ti 2. Measuring range : 0...+25.0 (0...+2500kPa) 3.Accuracy class : 0.20% 4.Electronics : Two-wire 4 ... 20 mA 5.Measuring cell type : Piezoresistive - metallic measuring cell 6.process pressure : -1 bar to 80.0 bar 7.with 360 degree status display 8.Electrical connection/ protection : 4-pole plug connection ISO4400 M16 / IP65 9.Media: Gases, Vapours and liquids, also viscous products 10.Auxiliary Energy: 10...30 VDC 11.Connection Type: Thread Male 12.Operating Temperature: 20...80 °C 	2	EA

80	Level TransPG1S22C2 0-1500 mmH2O	<p>Item No.80 Technical specification:</p> <p>Level transPG 1S22C2 0-1500 mm</p> <ol style="list-style-type: none"> 1.Process fitting / Material : Thread M44x1.25, DIN13; pressure screw: 316L /316L 2.Sealing concept: Double seal 3. Measuring range : 0...+1.0bar (0...+100kPa) 4.Accuracy class : 0.20% 5.Electronics : Two-wire 4 ... 20mA DC with digital communication (HART Protocol) 6.Measuring cell seal / Process temperature: FKM (VP2/A) / -20...+150°C 7.Measuring cell type : CERTEC - ceramic measuring cell 8.process pressure : -1 bar to 23.0 bar 9.with 360 degree status display 10.Electrical connection/ protection : 4-pole plug connection ISO4400 M16 / IP65/IP66/IP67 11.Auxiliary Energy: 10...30 VDC 12.Connection Type: Thread Male 13.Operating Temperature: 0...150 °C 14.Medium : Polyvinyle alcohol <p>Level TransPG1S22C2 0- 1500 mmH2O (Rosemount) or equivalent</p>	3	EA
----	----------------------------------	---	---	----

90	Level Transmitter for Master Vat	<p>Item No.90 Technical specification: Level Transmitter for master vat</p> <ol style="list-style-type: none"> 1.Process fitting / Material : Flange DN25 PN16 Form B1, EN1092-1/316L, wetted: PEEK 2. Measuring range : 0...+ 1 .0 bar 3.Sealing concept: Double seal 4.Accuracy class : 0.10% 5.Measuring cell seal/Processs temperature: FKM (VP2/A) / -20...+150°C 6.Electronics : Two-wire 4 ... 20mA DC with digital communication (HART Protocol) 7.Measuring cell type: CERTEC - ceramic measuring cell 8.process pressure : -1 bar to 16.0 bar 9.Protection: IP66/IP67 10.cable length between transmitter and sensor(Remote cell) ≥ 10.00 meter 11.Electrical connection/ protection : 4-pole plug connection ISO4400 M16 / IP65 12.Media: Gases, Vapours and liquids, also viscous products 13.Auxiliary Energy: 10...30 VDC 14.Electronic differential pressure: Suitable configuration 15.PCD = 85 mm , Mounting of transmitter shall be as per attached drawing. <p>Transmitter & Remote seal must be of same manufacturer</p> <p>All dimensions shall be as per attached drawings. All dimensions are in mm</p>	1	EA
----	----------------------------------	---	---	----

100	Level Transmitter for Master Sizer	<p>Item No.100 Technical specification: Level Transmitter for Master sizer</p> <p>1.Process fitting / Material : Clamp 2" PN16 (ø64mm) DIN32676, ISO2852 /316L 2.Measuring range : 0...+0.1 bar (0...+10kPa) 3.Sealing concept: Double seal 4.Accuracy class : 0.10% 5.Measuring cell seal/Processs temperature: FKM (VP2/A) / -20...+150°C 6.Electronics : Two-wire 4 ... 20mA DC with digital communication (HART Protocol) 7.Measuring cell type: CERTEC - ceramic measuring cell 8.process pressure : -1 bar to 10.0 bar 9.cable lenth between transmitter and sensor(Remote cell) ≥ 4.0 meter 10.Housing version / Protection: Axial cable outlet IP68 (PUR) with external housing / IP66/IP67; NEMA 4X</p> <p>11.Media: Gases, Vapours and liquids, also viscous products 12.Auxiliary Energy: 10...30 VDC</p> <p>Transmitter & Remote seal must be of same manufacturer</p> <p>All dimensions shall be as per attached drawings. All dimensions are in mm</p>	1	EA
110	Radar level tx Non contact (PVA)	<p>Item No.110 Technical specification: Radar type level transmitter</p> <p>1.Generation : Second Generation 2.Application: For pulp and water and viscous material with fumes 3.Radar technology : 80 GHz 4.Process fitting: Thread DIN3852-A, G1 1/2" PN40 / 316/316L 5.Antenna version : with integrated antenna system 6.Material / Seal / Process temperature: PEEK / FKM (SHS FPM 70C3 GLT) / -40...+150°C 7.Housing / Protection: Aluminium single chamber / IP66/IP68 8.Display, adjustment or radio module: Display, adjustment or radio module 9.Electronics: Two-wire 4 ... 20 mA/HART 10.Max. measuring range: 120.000 m 11.Min. process pressure in bar: -1.000 12.Max. process pressure in bar: 40.000 13. mounting : Flanged</p>	3	EA

Drawing for Item No. 10 & 20.

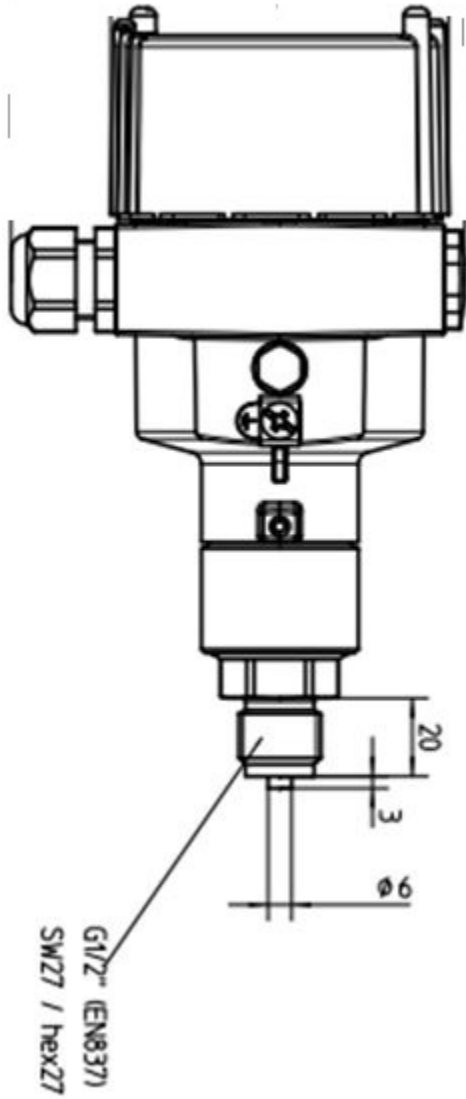

Drawing for item no. 30 , 40 & 50

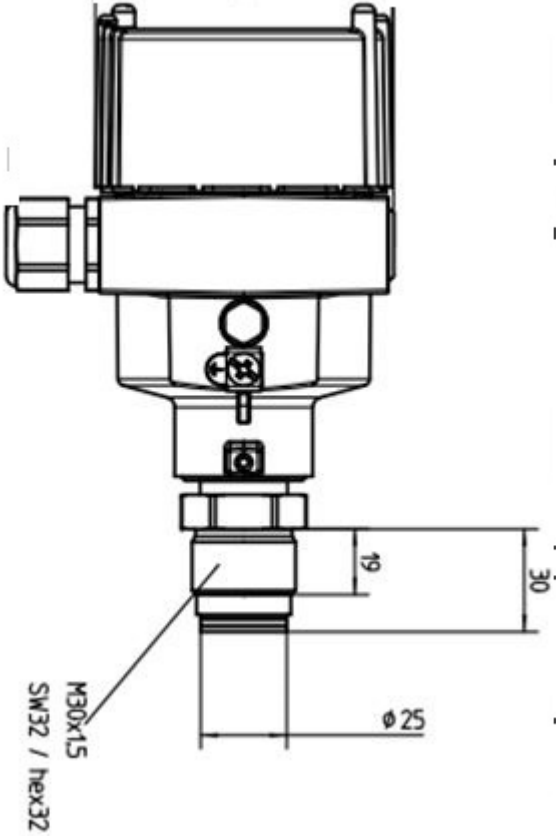

DRAWING FOR ITEM NO. 90

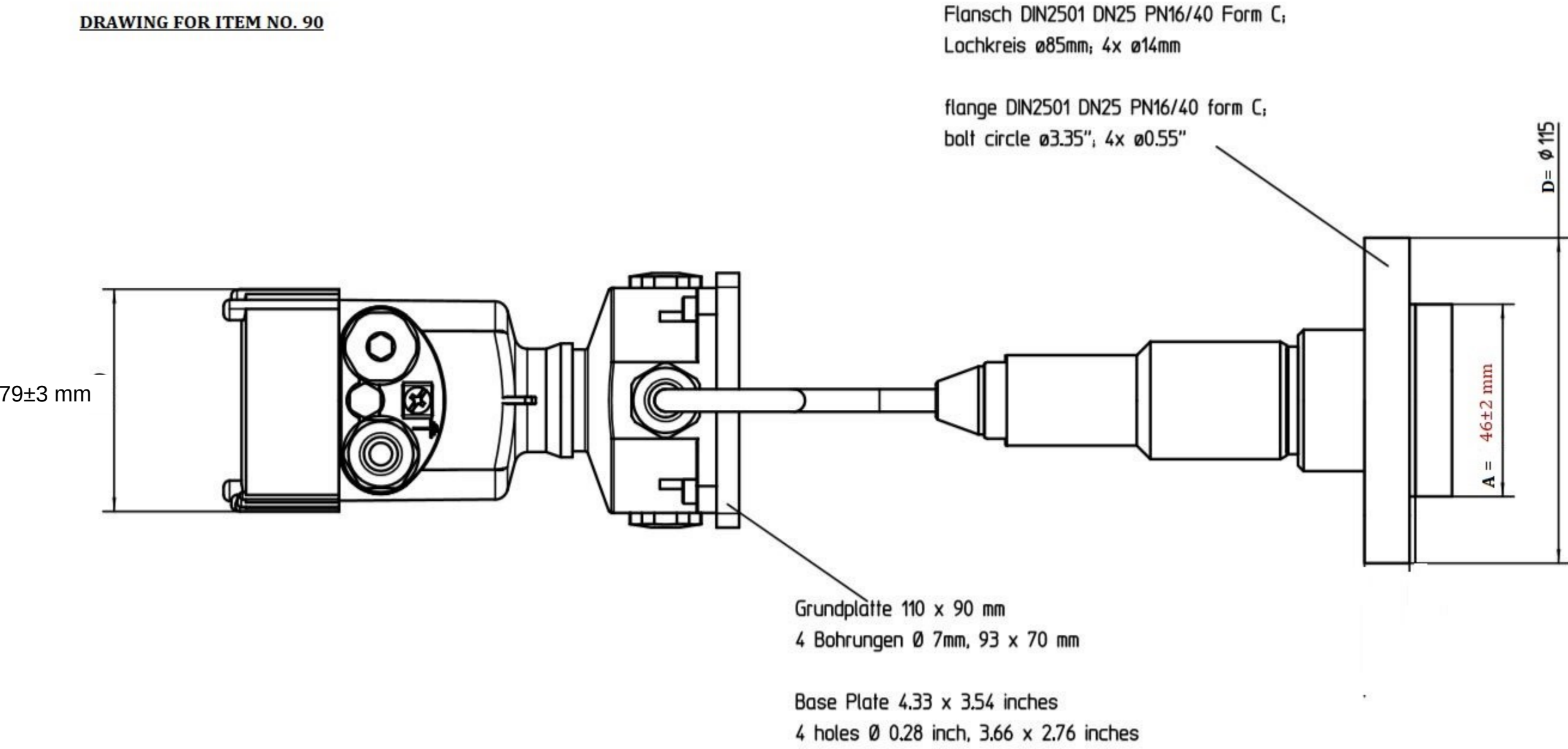

Grundplatte 110 x 90 mm
4 Bohrungen $\varnothing 7 \text{ mm}, 93 \times 70 \text{ mm}$

Base Plate 4.33 x 3.54 inches
4 holes $\varnothing 0.28 \text{ inch}, 3.66 \times 2.76 \text{ inches}$

Flansch DIN2501 DN25 PN16/40 Form C;
Lochkreis $\varnothing 85 \text{ mm; } 4 \times \varnothing 14 \text{ mm}$

flange DIN2501 DN25 PN16/40 form C;
bolt circle $\varnothing 3.35''; 4 \times \varnothing 0.55''$

A = $46 \pm 2 \text{ mm}$

D = $\varnothing 115$

DRAWING FOR ITEM NO. 100

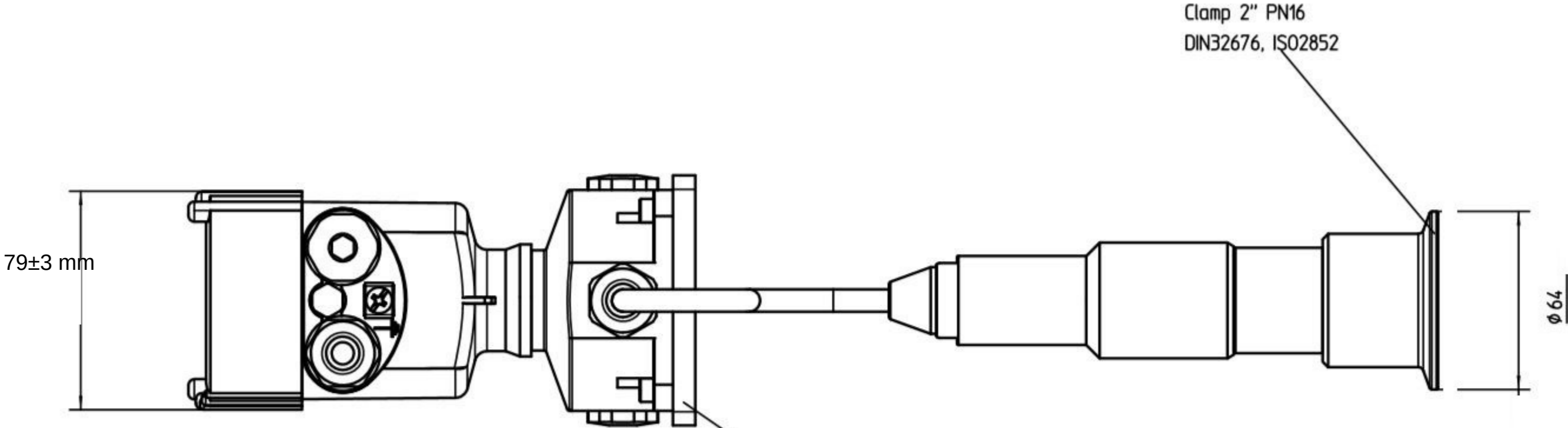

Clamp 2" PN16
DIN32676, ISO2852

79±3 mm

Ø 64

Type your text

Grundplatte 110 x 90 mm
4 Bohrungen Ø 7mm, 93 x 70 mm

Base Plate 4.33 x 3.54 inches
4 holes Ø 0.28 inch, 3.66 x 2.76 inches

ANNEXURE-I

Declaration for Section 206AB of TDS under income tax Act, 1961

(to be submitted on Letter Head)

Vendor Code: _____

M/s _____

PAN _____ GSTIN _____

I/We _____ (Legal Name and complete address) _____,

PAN: _____ (PAN no) _____, TAN:

_____ (TAN no.) _____, referring to the provisions of 206AB of the IT Act, 1961, hereby declare the following:-

Financial Year	Aggregate TDS & TCS credit in our name was Rs. 50,000 or more ("Yes/ No")	Income Tax Return ("ITR") Filed ("Yes/No")	E-filing Acknowledgment Number (15 digit - numeric) (Attach copy of acknowledgments)	Date of Filing of Return of Income u/s 139(1) (DD/MM/YYYY)	Linked PAN with Aadhaar number or will link it before 30 Jun 2023 (or any further date as may be notified by CBDT ("Yes / No")
2021-22					
2022-23					

We do hereby declare that to the best of my /our knowledge and belief what is stated above is correct, complete and is truly stated. In case there is a tax liability, interest or penal consequences which are levied on SPM on account of the false representation/ declaration, I/we undertake to fully indemnify SPM for the same.

FOR _____

Authorized Signatory

Date:

Note: In case the vendor failed to comply with the above provisions, TDS shall be deducted at the higher of the following rates, namely: -

- (i) at twice the rate specified in the relevant provision of the Act; or*
- (ii) at twice the rate or rates in force; or*
- (iii) at the rate of five per cent (5%).*

ANNEXURE-II

(To be submitted on the Letter Head)

DECLARATION

We do hereby declare that,

1. We have not been blacklisted/debarred by BNPMIPL/BRBNMPL/SPMCIL or any Govt. Departments for participation in tenders. The information provided above is correct and true to the best of my knowledge and belief.
2. We do hereby declare that we have read and understood all terms and conditions of tender document including GIT, SIT, GCC, SCC, Technical Specification, Quality Control Criteria and confirm to abide to those conditions without any counter conditions.
3. We are accepting all the terms and conditions of the tender document without any deviation and withdraw all deviations if any.

Signature.....

Name.....

Designation.....

Date.....

Stamp of the Organization.....

ANNEXURE-III

(To be submitted on the Letter Head)

**DECLARATION
(Refer GIT Clause No.3.5)**

"I have read the clause regarding restrictions on procurement from a bidder of a country which shares a land border with India. I certify that M/s..... (Firm's name) is not from such a country or, if from such a country, has been registered with the Competent Authority. I hereby certify that M/s..... (Firm's name) fulfils at requirements in this regard and is eligible to be considered." (Where applicable, evidence of valid registration by the competent Authority shall be attached)"

I, the undersigned, declare that the item originates in..... (Name of the country).

Signature.....

Name.....

Designation.....

Date.....

Stamp of the Organization.....

(To be submitted on the letter head of the manufacturing firm)

SECTION XIV: MANUFACTURER'S AUTHORIZATION FORM

To,

Security Paper Mill, Narmadapuram
A Unit of Security Printing & Minting
Corporation of India Limited
(Wholly Owned by Govt. of India)
Hoshangabad

Ref: Your Tender document No, dated

We,.....who are proven and reputable manufacturers of (Name and description of the goods offered in the tender) having factories at hereby authorize Messrs (name and address of the agent) to submit a tender, process the same further and enter into a contract with you against your requirement as contained in the above referred tender enquiry documents for the above goods manufactured by us.

We further confirm that no supplier or firm or individual other than Messrs..... (name and address of the above agent) is authorized to submit a tender, process the same further and enter into a contract with you against your requirement as contained in the above referred tender enquiry documents for the above goods manufactured by us.

We also hereby extend our full warranty, as applicable as per clause 16 of the General Conditions of Contract read with modification, if any, in the Special Conditions of Contract for the goods and services offered for supply by the above firm against this tender document.

Yours faithfully,

.....
.....

[Signature with date, name, and designation]
for and on behalf of Messrs.....

Name & address of the manufacturers

Note: This letter of authorization should be on the letter head of the manufacturing firm and should be signed by a person competent and having the power of attorney to legally bind the manufacturer.

Checklist of Documents for Technical Bid

S. No.	Documents Required	Submitted (✓)
1	Weather applied for MSME (MSME certificate)	()
2	Certificate of Local Content as per Public Procurement (Preference to Make in India), Order 2017	()
3	Duly Seal & Signed : Technical Specifications	()
4	Acceptance of all terms and condition as per Buyer Added Bid Specific ATC	()
5	Buyer added Specific ATC Declarations (Buyer uploaded ATC document : Annexure-I, II & III)	()
6	Manufacturer/OEM Authorization Certificate	()
7	No Deviation certificate	()

ADDITIONAL TERMS & CONDITIONS (ATC)

1. Required Terms of Delivery: F.O.R. Security Paper Mill Narmadapuram (Duly Unloaded).

2. Destination: Security Paper Mill, Narmadapuram (M.P.)-461005

3. Payment Terms: 100% on receipt and acceptance (suitability) of goods by the SPM, Narmadapuram and on production of all required documents by the supplier.

4. Bidder Should Quote Prices Inclusive of GST And All Cost Components Such As Packing & Forwarding Details, Freight & Insurance Charges upto Destination etc. on FOR Security Paper Mill, Narmadapuram (Madhya Pradesh), India basis only.

5. Liquidated Damages (LD) Clause: If the contractor fails to deliver the goods and/or services or any installment thereof within the Delivery Period, SPM Narmadapuram shall, without prejudice to other rights and remedies available to SPM, Narmadapuram under the contract, deduct from the contract price, as Liquidated damages, a sum equivalent to the rate of 0.5 Percent of the delivered price of the delayed goods and/or services along with applicable GST of

18% on the LD amount for each week of delay or part thereof until actual delivery or performance, subject to a maximum deduction of the 10% (plus GST on the LD amount) of the delayed goods or services.

6. The terms and conditions, guidelines of SPMCIL Procurement Manual Version 2.0 will be applicable to this bid at any stage to avoid any conflict at later stage. Kindly refer General Instructions to Tenderer (GIT) and General Conditions of Contract (GCC) of SPMCIL Procurement Manual Version 2.0 for additional terms and conditions as per the links given below:

GIT: <https://spmcil.com/uploaddocument/GIT/new.pdf>

GCC: <https://spmcil.com/uploaddocument/GCC/new.pdf>

7. SPM (as Buyer) is liable to deduct TDS u/s 194Q @ applicable rate on goods purchases (if applicable). In case of deduction of TDS under section 194Q; the Supplier (Vendor) need not to charge TCS u/s 206C (1H) on invoicing on or after 01.07.2021.

8. Vendor has to submit declaration in specified format (*refer Buyer added Specific ATC*) for the compliance of Section 206AB of Income Tax Act, 1961. In case of non-submission of declaration; TDS will be deducted at higher rates (as applicable) as per section 206AB.

9. **GST Return:** Supplier should file the GST returns for outward supplies in time. In case of any Input Credit Loss to SPM by way of their failure to files GST Returns in time, SPM reserves the right to withhold the payment of further supplies till production of evidence of filling of Returns.

10. Bidder shall submit duly seal & signed copy of Technical Specifications.

11. WARRANTY CLAUSE:

11.1 The warranty shall remain valid for twelve months after the goods have been delivered to the final destination and accepted by SPM in terms of the contract or for fifteen months from the date of dispatch from the supplier's premises for domestic goods whichever is earlier.

11.2 In case of any claim arising out of this warranty, SPMCIL shall promptly notify the same in writing to the supplier.

11.3 Upon receipt of such notice, the supplier shall, with all reasonable speed replace the defective goods or parts thereof, free of cost, at the ultimate destination. The supplier shall take over the replaced parts/ goods after providing their replacements and no claim, whatsoever shall lie on SPM for such replaced parts/ goods thereafter.

11.4 In the event of any rectification of a defect or replacement of any defective goods during the warranty period, the warranty for the rectified/ replaced goods shall be extended to a further period of twelve months from the date such rectified / replaced goods starts functioning to the satisfaction of SPM.

11.5 If the supplier, having been notified, fails to rectify/replace the defect(s) within a reasonable period SPM may proceed to take such remedial action(s) as deemed fit by SPM, at the risk and expense of the supplier and without prejudice to other contractual rights and remedies, which SPM may have against the supplier.

12. No Deviation Certificate: Bidder should confirm in their quotation, "We acceptance of all terms and condition with technical specification of Bid document without any deviation".