

Bid Document/ बिड दस्तावेज़

Bid Details/बिड विवरण	
Bid End Date/Time/बिड बंद होने की तारीख/समय	09-05-2023 15:00:00
Bid Opening Date/Time/बिड खुलने की तारीख/समय	09-05-2023 15:30:00
Bid Offer Validity (From End Date)/बिड पेशकश वैधता (बंद होने की तारीख से)	120 (Days)
Ministry/State Name/मंत्रालय/राज्य का नाम	Ministry Of Finance
Department Name/विभाग का नाम	Department Of Economic Affairs
Organisation Name/संगठन का नाम	Security Printing And Minting Corporation Of India Limited (spmciil)
Office Name/कार्यालय का नाम	Janpath
Total Quantity/कुल मात्रा	66
Item Category/मद केटगरी	Item no 1 , Item no 2 , Item no 3 , Item no 4 , Item no 5 , Item no 6 , Item no 7
BOQ Title/बीओक्यू शीर्षक	Procurement of linear Bearing
MSE Exemption for Years Of Experience/वर्षों के अनुभव के लिए एमएसई को छूट प्राप्त है	Yes
Startup Exemption for Years Of Experience/वर्षों के अनुभव के लिए स्टार्टअप को छूट प्राप्त है	Yes
Document required from seller/विक्रेता से मांगे गए दस्तावेज़	Certificate (Requested in ATC),OEM Authorization Certificate,Additional Doc 1 (Requested in ATC),Additional Doc 2 (Requested in ATC) *In case any bidder is seeking exemption from Experience / Turnover Criteria, the supporting documents to prove his eligibility for exemption must be uploaded for evaluation by the buyer
Bid to RA enabled/बिड से रिवर्स नीलामी सक्रिय किया	No
Type of Bid/बिड का प्रकार	Two Packet Bid
Primary product category	Item no 7
Time allowed for Technical Clarifications during technical evaluation/तकनीकी मूल्यांकन के दौरान तकनीकी स्पष्टीकरण हेतु अनुमत समय	2 Days
Evaluation Method/मूल्यांकन पद्धति	Total value wise evaluation

EMD Detail/ईएमडी विवरण

Advisory Bank/एडवाइजरी बैंक	Indusind bank
EMD Amount/ईएमडी राशि	12400

ePBG Detail/ईपीबीजी विवरण

Advisory Bank/एडवाइजरी बैंक	Indusind bank
ePBG Percentage(%) / ईपीबीजी प्रतिशत (%)	10.00
Duration of ePBG required (Months) / ईपीबीजी की अपेक्षित अवधि (महीने).	17

(a). EMD EXEMPTION: The bidder seeking EMD exemption, must submit the valid supporting document for the relevant category as per GeM GTC with the bid. Under MSE category, only manufacturers for goods and Service Providers for Services are eligible for exemption from EMD. Traders are excluded from the purview of this Policy./जेम की शर्तों के अनुसार ईएमडी छूट के इच्छुक बिडर को संबंधित केटेगरी के लिए बिड के साथ वैध समर्थित दस्तावेज प्रस्तुत करने हैं। एमएसई केटेगरी के अंतर्गत केवल वस्तुओं के लिए विनिर्माता तथा सेवाओं के लिए सेवा प्रदाता ईएमडी से छूट के पात्र हैं। व्यापारियों को इस नीति के दायरे से बाहर रखा गया है।

(b). EMD & Performance security should be in favour of Beneficiary, wherever it is applicable./ईएमडी और संपादन जमानत राशि, जहां यह लागू होती है, लाभार्थी के पक्ष में होनी चाहिए।

Beneficiary/लाभार्थी :

Narmadapuram
Security Paper Mill, Narmadapuram
(Security Paper Mill)

Splitting/विभाजन

Bid splitting not applied/बोली विभाजन लागू नहीं किया गया.

MII Purchase Preference/एमआईआई खरीद वरीयता

MII Purchase Preference/एमआईआई खरीद वरीयता	Yes
--	-----

MSE Purchase Preference/एमएसई खरीद वरीयता

MSE Purchase Preference/एमएसई खरीद वरीयता	Yes
---	-----

1. If the bidder is a Micro or Small Enterprise as per latest definitions under MSME rules, the bidder shall be exempted from the requirement of "Bidder Turnover" criteria and "Experience Criteria" subject to meeting of quality and technical specifications. If the bidder is OEM of the offered products, it would be exempted from the "OEM Average Turnover" criteria also subject to meeting of quality and technical specifications. In case any bidder is seeking exemption from Turnover / Experience Criteria, the supporting documents to prove his eligibility

for exemption must be uploaded for evaluation by the buyer.

2. If the bidder is a Startup, the bidder shall be exempted from the requirement of "Bidder Turnover" criteria and "Experience Criteria" subject to their meeting of quality and technical specifications. If the bidder is OEM of the offered products, it would be exempted from the "OEM Average Turnover" criteria also subject to meeting of quality and technical specifications. In case any bidder is seeking exemption from Turnover / Experience Criteria, the supporting documents to prove his eligibility for exemption must be uploaded for evaluation by the buyer.

3. Preference to Make In India products (For bids < 200 Crore): Preference shall be given to Class 1 local supplier as defined in public procurement (Preference to Make in India), Order 2017 as amended from time to time and its subsequent Orders/Notifications issued by concerned Nodal Ministry for specific Goods/Products. The minimum local content to qualify as a Class 1 local supplier is denoted in the bid document. If the bidder wants to avail the Purchase preference, the bidder must upload a certificate from the OEM regarding the percentage of the local content and the details of locations at which the local value addition is made along with their bid, failing which no purchase preference shall be granted. In case the bid value is more than Rs 10 Crore, the declaration relating to percentage of local content shall be certified by the statutory auditor or cost auditor, if the OEM is a company and by a practicing cost accountant or a chartered accountant for OEMs other than companies as per the Public Procurement (preference to Make-in -India) order 2017 dated 04.06.2020. Only Class-I and Class-II Local suppliers as per MII order dated 4.6.2020 will be eligible to bid. Non - Local suppliers as per MII order dated 04.06.2020 are not eligible to participate. However, eligible micro and small enterprises will be allowed to participate .In case Buyer has selected Purchase preference to Micro and Small Enterprises clause in the bid, the same will get precedence over this clause.

4. Purchase preference to Micro and Small Enterprises (MSEs): Purchase preference will be given to MSEs as defined in Public Procurement Policy for Micro and Small Enterprises (MSEs) Order, 2012 dated 23.03.2012 issued by Ministry of Micro, Small and Medium Enterprises and its subsequent Orders/Notifications issued by concerned Ministry. If the bidder wants to avail the Purchase preference, the bidder must be the manufacturer of the offered product in case of bid for supply of goods. Traders are excluded from the purview of Public Procurement Policy for Micro and Small Enterprises. In respect of bid for Services, the bidder must be the Service provider of the offered Service. Relevant documentary evidence in this regard shall be uploaded along with the bid in respect of the offered product or service. If L-1 is not an MSE and MSE Seller (s) has/have quoted price within L-1+ 15% (Selected by Buyer) of margin of purchase preference /price band defined in relevant policy, such Seller shall be given opportunity to match L-1 price and contract will be awarded for 25%(selected by Buyer) percentage of total QUANTITY.

5. Estimated Bid Value indicated above is being declared solely for the purpose of guidance on EMD amount and for determining the Eligibility Criteria related to Turn Over, Past Performance and Project / Past Experience etc. This has no relevance or bearing on the price to be quoted by the bidders and is also not going to have any impact on bid participation. Also this is not going to be used as a criteria in determining reasonableness of quoted prices which would be determined by the buyer based on its own assessment of reasonableness and based on competitive prices received in Bid / RA process.

Item No 1

(Minimum 50% and 20% Local Content required for qualifying as Class 1 and Class 2 Local Supplier respectively/कमशः श्रेणी 1 और श्रेणी 2 के स्थानीय आपूर्तिकर्ता के रूप में अर्हता प्राप्त करने के लिए आवश्यक)

Brand Type/ब्रांड का प्रकार	Unbranded
-----------------------------	-----------

Technical Specifications/तकनीकी विशिष्टियाँ

Specification Document	View File
BOQ Detail Document	View File

Advisory-Please refer attached BOQ document for detailed consignee list and delivery period.

Consignees/Reporting Officer/परेषिती/रिपोर्टिंग अधिकारी and/ तथा Quantity/मात्रा

S.No./क्र. सं.	Consignee Reporting/Officer/ परेषिती/रिपोर्टिंग अधिकारी	Address/पता	Quantity/मात्रा	Delivery Days/डिलीवरी के दिन
1	Balbir Singh Prajapati	461005,Security Paper Mill ,Narmadapuram , Madhya Pradesh	10	180

Item No 2

(Minimum 50% and 20% Local Content required for qualifying as Class 1 and Class 2 Local Supplier respectively/क्रमशः श्रेणी 1 और श्रेणी 2 के स्थानीय आपूर्तिकर्ता के रूप में अर्हता प्राप्त करने के लिए आवश्यक)

Brand Type/ब्रांड का प्रकार	Unbranded
-----------------------------	-----------

Technical Specifications/तकनीकी विशिष्टियाँ

Specification Document	View File
BOQ Detail Document	View File

Advisory-Please refer attached BOQ document for detailed consignee list and delivery period.

Consignees/Reporting Officer/परेषिती/रिपोर्टिंग अधिकारी and/ तथा Quantity/मात्रा

S.No./क्र. सं.	Consignee Reporting/Officer/ परेषिती/रिपोर्टिंग अधिकारी	Address/पता	Quantity/मात्रा	Delivery Days/डिलीवरी के दिन
1	Balbir Singh Prajapati	461005,Security Paper Mill ,Narmadapuram , Madhya Pradesh	10	180

Item No 3

(Minimum 50% and 20% Local Content required for qualifying as Class 1 and Class 2 Local Supplier respectively/क्रमशः श्रेणी 1 और श्रेणी 2 के स्थानीय आपूर्तिकर्ता के रूप में अर्हता प्राप्त करने के लिए आवश्यक)

Brand Type/ब्रांड का प्रकार	Unbranded
-----------------------------	-----------

Technical Specifications/तकनीकी विशिष्टियाँ

Specification Document	View File
BOQ Detail Document	View File

Advisory-Please refer attached BOQ document for detailed consignee list and delivery period.

Consignees/Reporting Officer/परेषिती/रिपोर्टिंग अधिकारी and/ तथा Quantity/मात्रा

S.No./क्र. सं.	Consignee Reporting/Officer/ परेषिती/रिपोर्टिंग अधिकारी	Address/पता	Quantity/मात्रा	Delivery Days/डिलीवरी के दिन
1	Balbir Singh Prajapati	461005,Security Paper Mill ,Narmadapuram , Madhya Pradesh	10	180

Item No 4

(Minimum 50% and 20% Local Content required for qualifying as Class 1 and Class 2 Local Supplier respectively/क्रमशः श्रेणी 1 और श्रेणी 2 के स्थानीय आपूर्तिकर्ता के रूप में अर्हता प्राप्त करने के लिए आवश्यक)

Brand Type/ब्रांड का प्रकार	Unbranded
-----------------------------	-----------

Technical Specifications/तकनीकी विशिष्टियाँ

Specification Document	View File
BOQ Detail Document	View File

Advisory-Please refer attached BOQ document for detailed consignee list and delivery period.

Consignees/Reporting Officer/परेषिती/रिपोर्टिंग अधिकारी and/ तथा Quantity/मात्रा

S.No./क्र. सं.	Consignee Reporting/Officer/ परेषिती/रिपोर्टिंग अधिकारी	Address/पता	Quantity/मात्रा	Delivery Days/डिलीवरी के दिन
1	Balbir Singh Prajapati	461005,Security Paper Mill ,Narmadapuram , Madhya Pradesh	10	180

Item No 5

(Minimum 50% and 20% Local Content required for qualifying as Class 1 and Class 2 Local Supplier respectively/क्रमशः श्रेणी 1 और श्रेणी 2 के स्थानीय आपूर्तिकर्ता के रूप में अर्हता प्राप्त करने के लिए आवश्यक)

Brand Type/ब्रांड का प्रकार	Unbranded
-----------------------------	-----------

Technical Specifications/तकनीकी विशिष्टियाँ

Specification Document	View File
BOQ Detail Document	View File

Advisory-Please refer attached BOQ document for detailed consignee list and delivery period.

Consignees/Reporting Officer/परेषिती/रिपोर्टिंग अधिकारी and/ तथा Quantity/मात्रा

S.No./क्र. सं.	Consignee Reporting/Officer/ परेषिती/रिपोर्टिंग अधिकारी	Address/पता	Quantity/मात्रा	Delivery Days/डिलीवरी के दिन
1	Balbir Singh Prajapati	461005,Security Paper Mill ,Narmadapuram , Madhya Pradesh	8	180

Item No 6

(Minimum 50% and 20% Local Content required for qualifying as Class 1 and Class 2 Local Supplier respectively/क्रमशः श्रेणी 1 और श्रेणी 2 के स्थानीय आपूर्तिकर्ता के रूप में अर्हता प्राप्त करने के लिए आवश्यक)

Brand Type/ब्रांड का प्रकार	Unbranded
-----------------------------	-----------

Technical Specifications/तकनीकी विशिष्टियाँ

Specification Document	View File
------------------------	---------------------------

BOQ Detail Document[View File](#)

Advisory-Please refer attached BOQ document for detailed consignee list and delivery period.

Consignees/Reporting Officer/परेषिती/रिपोर्टिंग अधिकारी and/ तथा Quantity/मात्रा

S.No./क्र. सं.	Consignee Reporting/Officer/ परेषिती/रिपोर्टिंग अधिकारी	Address/पता	Quantity/मात्रा	Delivery Days/डिलीवरी के दिन
1	Balbir Singh Prajapati	461005,Security Paper Mill ,Narmadapuram , Madhya Pradesh	8	180

Item No 7

(Minimum 50% and 20% Local Content required for qualifying as Class 1 and Class 2 Local Supplier respectively/क्रमशः श्रेणी 1 और श्रेणी 2 के स्थानीय आपूर्तिकर्ता के रूप में अर्हता प्राप्त करने के लिए आवश्यक)

Brand Type/ब्रांड का प्रकार

Unbranded

Technical Specifications/तकनीकी विशिष्टियाँ

Specification Document[View File](#)**BOQ Detail Document**[View File](#)

Advisory-Please refer attached BOQ document for detailed consignee list and delivery period.

Consignees/Reporting Officer/परेषिती/रिपोर्टिंग अधिकारी and/ तथा Quantity/मात्रा

S.No./क्र. सं.	Consignee Reporting/Officer/ परेषिती/रिपोर्टिंग अधिकारी	Address/पता	Quantity/मात्रा	Delivery Days/डिलीवरी के दिन
----------------	---	-------------	-----------------	------------------------------

S.No./क्र. सं.	Consignee Reporting/Officer/ परेषिती/रिपोर्टिंग अधिकरी	Address/पता	Quantity/मात्रा	Delivery Days/डिलीवरी के दिन
1	Balbir Singh Prajapati	461005, Security Paper Mill , Narmadapuram , Madhya Pradesh	10	180

Buyer Added Bid Specific Terms and Conditions/क्रता द्वारा जोडी गई बिड की विशेष शर्तें

1. Generic

Manufacturer Authorization: Wherever Authorised Distributors/service providers are submitting the bid, Authorisation Form /Certificate with OEM/Original Service Provider details such as name, designation, address, e-mail Id and Phone No. required to be furnished along with the bid

2. Certificates

Bidder's offer is liable to be rejected if they don't upload any of the certificates / documents sought in the Bid document, ATC and Corrigendum if any.

3. Warranty

Warranty period of the supplied products shall be 1 years from the date of final acceptance of goods or after completion of installation, commissioning & testing of goods (if included in the scope of supply), at consignee location. OEM Warranty certificates must be submitted by Successful Bidder at the time of delivery of Goods. The seller should guarantee the rectification of goods in case of any break down during the guarantee period. Seller should have well established Installation, Commissioning, Training, Troubleshooting and Maintenance Service group in INDIA for attending the after sales service. Details of Service Centres near consignee destinations are to be uploaded along with the bid.

4. Forms of EMD and PBG

Bidders can also submit the EMD with Account Payee Demand Draft in favour of

Security Paper Mill
payable at
Narmadapuram

Bidder has to upload scanned copy / proof of the DD along with bid and has to ensure delivery of hardcopy to the Buyer within 5 days of Bid End date / Bid Opening date.

5. Forms of EMD and PBG

Bidders can also submit the EMD with Fixed Deposit Receipt made out or pledged in the name of A/C (Name of the Buyer). The bank should certify on it that the deposit can be withdrawn only on the demand or with the sanction of the pledgee. For release of EMD, the FDR will be released in the favour of the bidder by the Buyer after making endorsement on the back of the FDR duly signed and stamped along with covering letter. Bidder has to upload scanned copy/ proof of the FDR along with bid and has to ensure delivery of hardcopy to the Buyer within 5 days of Bid End date/ Bid Opening date

6. Forms of EMD and PBG

Bidders can also submit the EMD with Banker's Cheque in favour of

Security Paper Mill
payable at
Narmadapuram

Bidder has to upload scanned copy / proof of the BC along with bid and has to ensure delivery of hardcopy to the Buyer within 5 days of Bid End date / Bid Opening date.

7. Forms of EMD and PBG

Successful Bidder can submit the Performance Security in the form of Account Payee Demand Draft also (besides PBG which is allowed as per GeM GTC). DD should be made in favour of

Security Paper Mill
payable at
Narmadapuram

. After award of contract, Successful Bidder can upload scanned copy of the DD in place of PBG and has to ensure delivery of hard copy to the original DD to the Buyer within 15 days of award of contract.

8. Forms of EMD and PBG

Successful Bidder can submit the Performance Security in the form of Fixed Deposit Receipt also (besides PBG which is allowed as per GeM GTC). FDR should be made out or pledged in the name of

Security Paper Mill, Narmadapuram

A/C (Name of the Seller). The bank should certify on it that the deposit can be withdrawn only on the demand or with the sanction of the pledgee. For release of Security Deposit, the FDR will be released in favour of bidder by the Buyer after making endorsement on the back of the FDR duly signed and stamped along with covering letter. Successful Bidder has to upload scanned copy of the FDR document in place of PBG and has to ensure delivery of hard copy of Original FDR to the Buyer within 15 days of award of contract.

9. Buyer Added Bid Specific ATC

Buyer Added text based ATC clauses

ADDITIONAL TERMS & CONDITIONS (ATC)

1. Required Terms of Delivery: F.O.R. Security Paper Mill Narmadapuram (Duly Unloaded).

2. Destination: Security Paper Mill, Narmadapuram (M.P.)-461005

3. Payment Terms: 100% on receipt and acceptance (suitability) of goods by the SPM, Narmadapuram and on production of all required documents by the supplier.

4. Bidder Should Quote Prices Inclusive of GST And All Cost Components Such As Packing & Forwarding De tails, Freight & Insurance Charges upto Destination etc. on FOR Security Paper Mill, Narmadapuram (Madh ya Pradesh), India basis only.

5. Liquidated Damages (LD) Clause: If the contractor fails to deliver the goods and/or services or any installment thereof within the Delivery Period, SPM Narmadapuram shall, without prejudice to other rights and remedies available to SPM, Narmadapuram under the contract, deduct from the contract price, as Liquidated damages, a sum equivalent to the rate of 0.5 Percent of the delivered price of the delayed goods and/or services for each week of delay or part thereof until actual delivery or performance, subject to a maximum deduction of the 10% of the delayed goods or services.

6. The terms and conditions, guidelines of SPMCIL Procurement Manual Version 2.0 will be applicable to this bid at any stage to avoid any conflict at later stage. Kindly refer General Instructions to Tenderer (GIT) and General Conditions of Contract (GCC) of SPMCIL Procurement Manual Version 2.0 for additional terms and conditions as per the links given below:

GIT: <https://spmCIL.com/uploaddocument/GIT/new.pdf>

GCC: <https://spmCIL.com/uploaddocument/GCC/new.pdf>

7. SPM (as Buyer) is liable to deduct TDS u/s 194Q @ applicable rate on goods purchases (if applicable). In case of deduction of TDS under section 194Q; the Supplier (Vendor) need not to charge TCS u/s 206C (1H) on invoicing on or after 01.07.2021.

8. Vendor has to submit declaration in specified format (refer Buyer added Specific ATC) for the compliance of Section 206AB of Income Tax Act, 1961. In case of non-submission of declaration; TDS will be deducted at higher rates (as applicable) as per section 206AB.

9. **GST Return:** Supplier should file the GST returns for outward supplies in time. SPM reserves the right to withhold the payment of further supplies till production of evidence of filing of Returns.

10. Bidder shall submit duly seal & signed copy of Technical Specifications.

10. **Buyer Added Bid Specific ATC**

Buyer uploaded ATC document [Click here to view the file.](#)

Disclaimer/अस्वीकरण

The additional terms and conditions have been incorporated by the Buyer after approval of the Competent Authority in Buyer Organization, whereby Buyer organization is solely responsible for the impact of these clauses on the bidding process, its outcome, and consequences thereof including any eccentricity / restriction arising in the bidding process due to these ATCs and due to modification of technical specifications and / or terms and conditions governing the bid. Any clause(s) incorporated by the Buyer regarding following shall be treated as null and void and would not be considered as part of bid:-

1. Definition of Class I and Class II suppliers in the bid not in line with the extant Order / Office Memorandum issued by DPIIT in this regard.
2. Seeking EMD submission from bidder(s), including via Additional Terms & Conditions, in contravention to exemption provided to such sellers under GeM GTC.
3. Publishing Custom / BOQ bids for items for which regular GeM categories are available without any Category item bunched with it.
4. Creating BoQ bid for single item.
5. Mentioning specific Brand or Make or Model or Manufacturer or Dealer name.
6. Mandating submission of documents in physical form as a pre-requisite to qualify bidders.
7. Floating / creation of work contracts as Custom Bids in Services.
8. Seeking sample with bid or approval of samples during bid evaluation process.
9. Mandating foreign / international certifications even in case of existence of Indian Standards without specifying equivalent Indian Certification / standards.
10. Seeking experience from specific organization / department / institute only or from foreign / export experience.
11. Creating bid for items from irrelevant categories.
12. Incorporating any clause against the MSME policy and Preference to Make in India Policy.
13. Reference of conditions published on any external site or reference to external documents/clauses.
14. Asking for any Tender fee / Bid Participation fee / Auction fee in case of Bids / Forward Auction, as the case may be.

Further, if any seller has any objection/grievance against these additional clauses or otherwise on any aspect of this bid, they can raise their representation against the same by using the Representation window provided in

the bid details field in Seller dashboard after logging in as a seller within 4 days of bid publication on GeM. Buyer is duty bound to reply to all such representations and would not be allowed to open bids if he fails to reply to such representations.

This Bid is also governed by the General Terms and Conditions/ यह बिड सामान्य शर्तों के अंतर्गत भी शासित है

In terms of GeM GTC clause 26 regarding Restrictions on procurement from a bidder of a country which shares a land border with India, any bidder from a country which shares a land border with India will be eligible to bid in this tender only if the bidder is registered with the Competent Authority. While participating in bid, Bidder has to undertake compliance of this and any false declaration and non-compliance of this would be a ground for immediate termination of the contract and further legal action in accordance with the laws./जेम की सामान्य शर्तों के खंड 26 के संदर्भ में भारत के साथ भूमि सीमा साझा करने वाले देश के बिडर से खरीद पर प्रतिबंध के संबंध में भारत के साथ भूमि सीमा साझा करने वाले देश का कोई भी बिडर इस निविदा में बिड देने के लिए तभी पात्र होगा जब वह बिड देने वाला सक्षम प्राधिकारी के पास पंजीकृत हो। बिड में भाग लेते समय बिडर को इसका अनुपालन करना होगा और कोई भी गलत घोषणा किए जाने व इसका अनुपालन न करने पर अनुबंध को तत्काल समाप्त करने और कानून के अनुसार आगे की कानूनी कार्रवाई का आधार होगा।

---Thank You/धन्यवाद---

Technical information

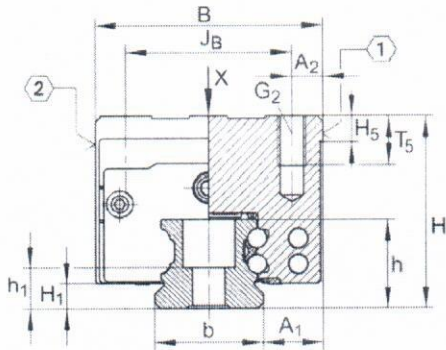

Main Dimensions & Performance Data

H	28 mm	height system
B	34 mm	width carriage
L	61.2 mm	overall length carriage
C	7,200 N	dynamic load rating
C ₀	14,500 N	static load rating
M _{0x}	150 Nm	static moment rating about X axis
M _{0y}	100 Nm	static moment rating about Y axis
M _{0z}	100 Nm	static moment rating about Z axis
	0.26 kg	Weight

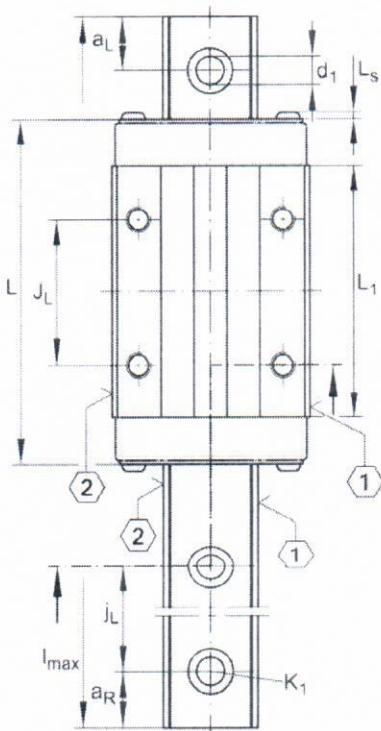

Mounting dimensions

VMKB_065	KWVE	Material name
A ₁	9.5 mm	
J _B	26 mm	
b	15 mm	width rail
A ₂	4 mm	
L ₁	39.8 mm	
L _s	1.3 mm	
J _L	26 mm	
H ₁	4.3 mm	
H ₅	4.75 mm	
T ₅	6 mm	

LINEAR BEARING KWVE15B-H-G3V1 400/9002

Drawing No. - 01

Technical information

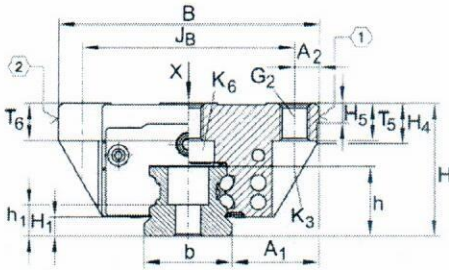

Main Dimensions & Performance Data

H	24 mm	height system
B	47 mm	width carriage
L	61.2 mm	overall length carriage
C	7,200 N	dynamic load rating
C ₀	14,500 N	static load rating
M _{0x}	150 Nm	static moment rating about X axis
M _{0y}	100 Nm	static moment rating about Y axis
M _{0z}	100 Nm	static moment rating about Z axis
	0.199 kg	Weight

Mounting dimensions

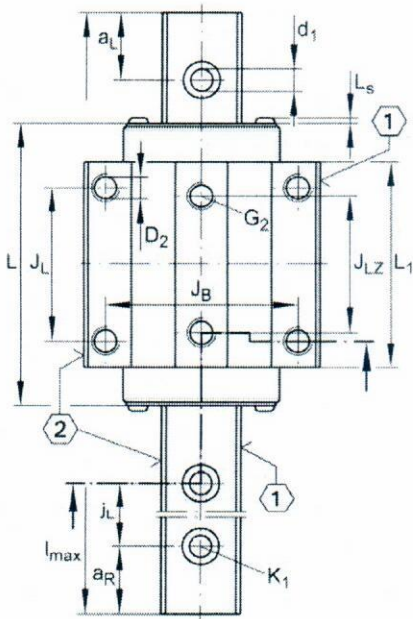

VMKB_065	KWVE	Material name
A ₁	16 mm	
J _B	38 mm	
b	15 mm	width rail
A ₂	4.5 mm	
L ₁	39.8 mm	
L _s	1.3 mm	
J _L	30 mm	
J _{LZ}	26 mm	
H ₁	4.3 mm	
H ₄	7.6 mm	
H ₅	4.75 mm	
T ₅	7 mm	
T ₆	5.8 mm	

LINEAR BEARING KWVE15BG3V1 400/900220

Drawing No.-02

Technical information

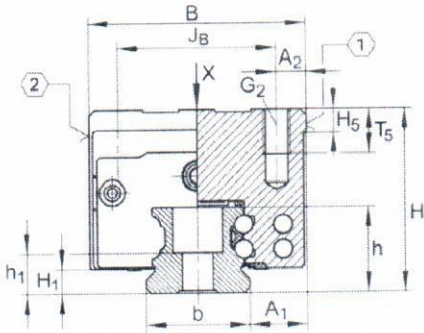

Main Dimensions & Performance Data

H	30 mm	height system
B	63 mm	width carriage
L	84.3 mm	Total length carriage
C	13,100 N	dynamic load rating
C ₀	27,000 N	static load rating
M _{0x}	332 Nm	static moment rating about X axis
M _{0y}	240 Nm	static moment rating about Y axis
M _{0z}	240 Nm	static moment rating about Z axis
	0.465 kg	Weight

Mounting dimensions

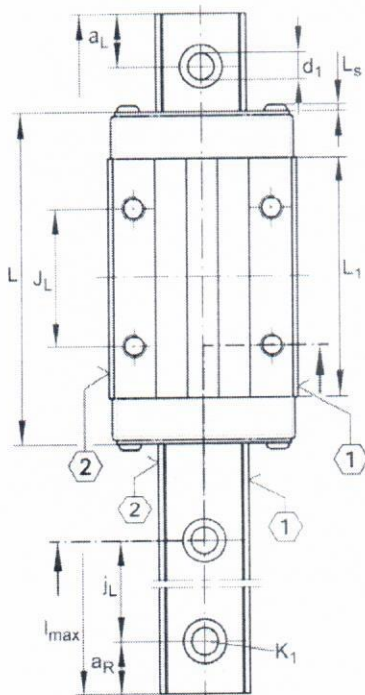

VMKB_065	KWVE	Material name
A ₁	21.5 mm	
J _B	32 mm	
b	20 mm	width rail
A ₂	5 mm	
L ₁	71.4 mm	
L _S	1.3 mm	
J _L	36 mm	
J _{LZ}	35 mm	
H ₁	4.5 mm	
H ₄	11 mm	
H ₅	5.25 mm	
T ₅	10 mm	
T ₆	7.5 mm	

LINEAR BEARING KWVE20-B-S-G3V1

Drawing No.- 03

Technical information

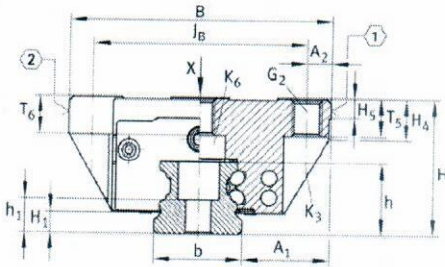

Main Dimensions & Performance Data

H	30 mm	height system
B	63 mm	width carriage
L	71.4 mm	overall length carriage
C	13,100 N	dynamic load rating
C ₀	27,000 N	static load rating
M _{0x}	332 Nm	static moment rating about X axis
M _{0y}	240 Nm	static moment rating about Y axis
M _{0z}	240 Nm	static moment rating about Z axis
	0.465 kg	Weight

Mounting dimensions

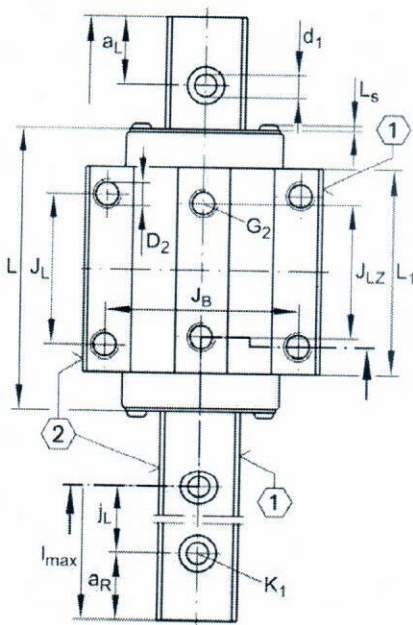

VMKB_065	KWVE	Material name
A ₁	21.5 mm	
J _B	53 mm	
b	20 mm	width rail
A ₂	5 mm	
L ₁	50.4 mm	
L _s	1.3 mm	
J _L	40 mm	
J _{LZ}	35 mm	
H ₁	4.5 mm	
H ₄	11 mm	
H ₅	5.25 mm	
T ₅	10 mm	
T ₆	7.5 mm	

LINEAR BEARING KWVE20B-G3V1 400/900220

Drawing No.- 04

Technical information

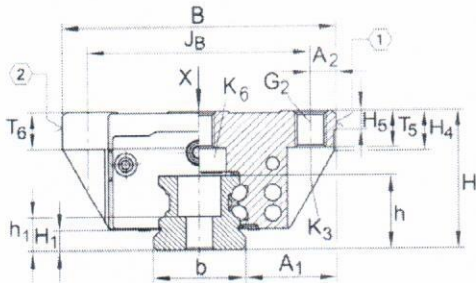

Main Dimensions & Performance Data

H	36 mm	height system
B	70 mm	width carriage
L	83.3 mm	overall length carriage
C	17,900 N	dynamic load rating
C_0	37,000 N	static load rating
M_{0x}	510 Nm	static moment rating about X axis
M_{0y}	395 Nm	static moment rating about Y axis
M_{0z}	395 Nm	static moment rating about Z axis
	0.71 kg	Weight

Mounting dimensions

VMKB_065	KWVE	Material name
A_1	23.5 mm	
J_B	57 mm	
b	23 mm	width rail
A_2	6.5 mm	
L_1	60.7 mm	
L_5	1.65 mm	
J_L	45 mm	
J_{LZ}	40 mm	
H_1	5.1 mm	
H_4	10.9 mm	
H_5	5.25 mm	
T_5	10 mm	
T_6	10 mm	

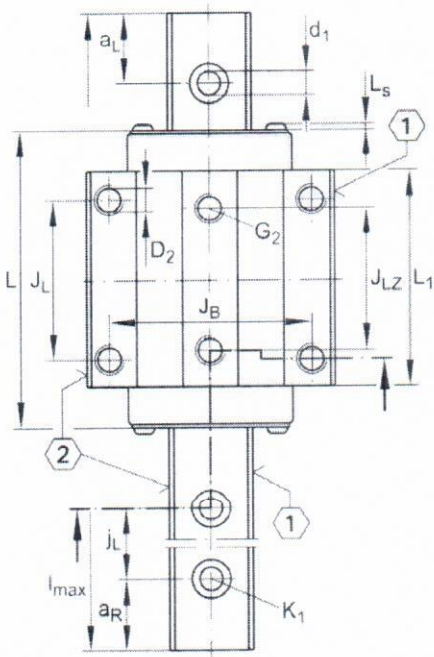

LINEAR BEARING- KWVE25-B-G3-V1

Drwaing No.-05

Technical information

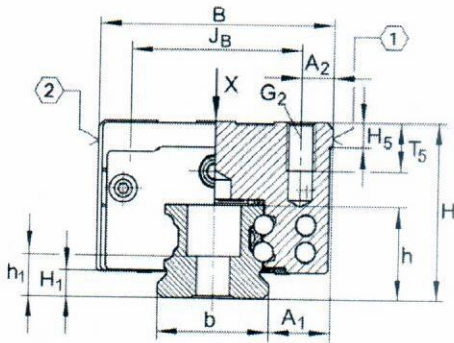

Main Dimensions & Performance Data

H	40 mm	height system
B	48 mm	width carriage
L	109.1 mm	overall length carriage
C	23,400 N	dynamic load rating
C ₀	54,000 N	static load rating
M _{0x}	745 Nm	static moment rating about X axis
M _{0y}	825 Nm	static moment rating about Y axis
M _{0z}	825 Nm	static moment rating about Z axis
	0.94 kg	Weight

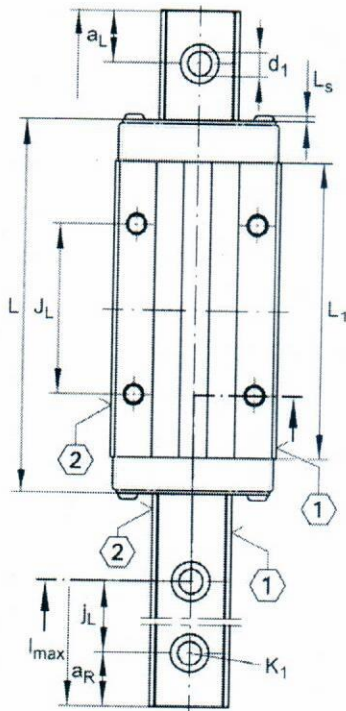

Mounting dimensions

VMKB_065	KWVE	Material name
A ₁	12.5 mm	
J _B	35 mm	
b	23 mm	width rail
A ₂	6.5 mm	
L ₁	86.5 mm	
L _s	1.65 mm	
J _L	50 mm	
H ₁	5.1 mm	
H ₅	5.25 mm	
T ₅	10 mm	

Linear Bearing- KWVE25-B-HL-G3V1

Drawing No.-06

Technical information

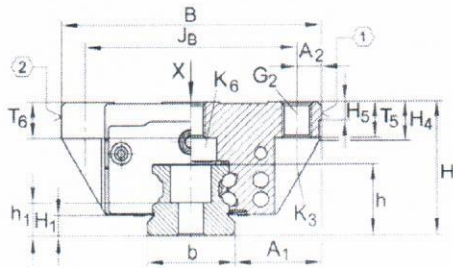

Main Dimensions & Performance Data

H	42 mm	height system
B	90 mm	width carriage
L	99 mm	overall length carriage
C	27,500 N	dynamic load rating
C_0	55,000 N	static load rating
M_{0x}	970 Nm	static moment rating about X axis
M_{0y}	700 Nm	static moment rating about Y axis
M_{0z}	700 Nm	static moment rating about Z axis
	1.21 kg	Weight

Mounting dimensions

VMKB_065	KWVE	Material name
A_1	31 mm	
J_B	72 mm	
b	28 mm	width rail
A_2	9 mm	
L_1	72 mm	
L_S	1.65 mm	
J_L	52 mm	
J_{LZ}	44 mm	
H_1	5.9 mm	
H_4	13.8 mm	
H_5	6.25 mm	
T_5	12 mm	
T_6	11.5 mm	

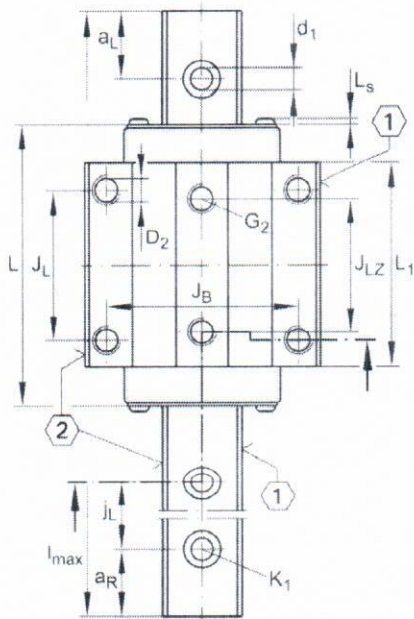

Linear Bearing KWVE30-B-G3V1 400/900220

Drawing No.-07

Technical Specification

Item 1:-

Specification:-

LINEAR BEARING KWVE15B-H-G3V1 400/900220 (KUVE15B-H-G3) Suitable for linear Guide TKVD15-G3

One to one interchangeable existing INA makes linear bearing (KWVE15B-H-G3V1) Suitable for Linear guide (TKVD15-G3) as per **drawing no.-1**

High, narrow carriage, four row; Corrosion resistant design possible, H- 28 mm, B -34 mm, L- 61.2 mm,

Item 2:-

Specification:-

LINEAR BEARING KWVE15-B-G3V1 400/900220 (KUVE15B-G3) Suitable for LINEAR GUIDE TKVD15-G3

One to one interchangeable existing INA makes linear bearing (KWVE15-B-G3V1) suitable for Linear guide (TKVD15-G3) as per **drawing no.-2**

Standard carriage, four rows, Design with anticorrosion protection possible, full complements ball set, H- 24mm, B -27mm, L- 61.2 mm,

Item 3:-

Specification:-

Linear Bearing KWVE20B-H-G3V1 400/900220 (KWVE20B-S-G3V1) suitable for linear guide TKVD20-G3-B

One to one interchangeable existing INA makes linear bearing (KWVE20B-H-G3V1) suitable for Linear guide (TKVD20-G3-B) as per **drawing no.-3**

High, narrow carriage, four row; Corrosion resistant design possible, H- 30 mm B -44 mm, L- 84.3 mm,

Item 4:-

Specification:-

Linear Bearing KWVE20B-G3V1 400/900220 (KUVE20B-G3V1) Suitable for linear guide TKVD20-G3-B

One to one interchangeable existing INA makes linear bearing (KWVE20B-G3V1) Suitable for Linear guide(TKVD20-G3-B) as per **drawing no.-4**

Standard carriage, four row, Design with anticorrosion protection possible, full complement ball set, H-30 mm, B -63mm, L-71.4 mm,

Item 5:-

Specification:-

Linear Bearing KWVE25B-G3V1 suitable for linear guide TKVD25-G3

One to one interchangeable existing INA makes linear bearing (KWVE25B-G3V1) suitable for Linear guide (TKVD25-G3-B) as per **drawing no.-5**

Standard carriage, four row, Design with anticorrosion protection possible, full complement ball set, H-36mm,B-70mm,L-83.3 mm,

Item 6:-

Specification:-

Linear Bearing KWVE25B-HL-G3V1 suitable for linear guide TKVD25-G3

One to one interchangeable existing INA makes linear bearing (KWVE25B-HL-G3V1) suitable for Linear guide (TKVD25-G3-B) as per **drawing no.-6**

High, narrow, long carriage, four rows, corrosion resistant, design possible, H- 40 mm B -48 mm, L-109.1 mm.

Item 7:-

Specification:-

Linear Bearing KWVE30B-G3V1 400/900220 suitable for linear guide TKVD30-G3

One to one interchangeable existing INA makes linear bearing KWVE30B-G3V1 suitable for Linear guide (TKVD30-G3) as per **drawing no.-7**

Standard carriage, four row, Design with anticorrosion protection possible, full complement ball set, H-42mm B -90 mm, L- 99 mm

Special Term and condition:-

1. Firm should provide Technical Leaflet and Drawing of quoted product along with techno commercial bid.
2. In case of abnormal failure of Linear Bearing with linear guide while in service, bidder shall depute their service engineer free of cost to analyze the root cause & firm will take remedial action without any extra charged. Bidder shall confirm same with technical bid.
3. Firm may visit the plant to have clear understanding of the install equipment and related assembly, before submit techno-commercial bid.
4. Make- INA or Equivalent

ANNEXURE-I

Declaration for Section 206AB of TDS under income tax Act, 1961

(to be submitted on Letter Head)

Vendor Code: _____

M/s _____

PAN _____ GSTIN _____

I/We _____ (Legal Name and complete address) _____, PAN: _____ (PAN no) _____, TAN: _____ (TAN no.) _____, referring to the provisions of 206AB of the IT Act, 1961, hereby declare the following:-

Financial Year	Aggregate TDS & TCS credit in our name was Rs. 50,000 or more ("Yes/ No")	Income Tax Return ("ITR") Filed ("Yes/No")	E-filing Acknowledgment Number (15 digit - numeric) (Attach copy of acknowledgments)	Date of Filing of Return of Income u/s 139(1) (DD/MM/YYYY)	Linked PAN with Aadhaar number or will link it before 30 Jun 2022 (or any further date as may be notified by CBDT ("Yes / No")
2020-21					
2021-22					

We do hereby declare that to the best of my /our knowledge and belief what is stated above is correct, complete and is truly stated. In case there is a tax liability, interest or penal consequences which are levied on SPM on account of the false representation/ declaration, I/we undertake to fully indemnify SPM for the same.

FOR _____

Authorized Signatory

Date:

Note: In case the vendor failed to comply with the above provisions, TDS shall be deducted at the higher of the following rates, namely: -

- (i) at twice the rate specified in the relevant provision of the Act; or*
- (ii) at twice the rate or rates in force; or*
- (iii) at the rate of five per cent (5%).*

(To be submitted on the Letter Head)

DECLARATION

We do hereby declare that,

1. We have not been blacklisted/debarred by BNPMIPL/BRBNMPL/SPMCIL or any Govt. Departments for participation in tenders. The information provided above is correct and true to the best of my knowledge and belief.
2. We do hereby declare that we have read and understood all terms and conditions of tender document including GIT, SIT, GCC, SCC, Technical Specification, Quality Control Criteria and confirm to abide to those conditions without any counter conditions.
3. We are accepting all the terms and condition as per Buyer Added Bid Specific ATC (Acceptance of Gem Bid).
4. We are accepting all the terms and conditions of the tender document without any deviation and withdraw all deviations if any.

Signature.....

Name.....

Designation.....

Date.....

Stamp of the Organization.....

(To be submitted on the Letter Head)

**DECLARATION
(Refer GIT Clause No.3.5)**

"I have read the clause regarding restrictions on procurement from a bidder of a country which shares a land border with India. I certify that M/s..... (Firm's name) is not from such a country or, if from such a country, has been registered with the Competent Authority. I hereby certify that M/s..... (Firm's name) fulfils at requirements in this regard and is eligible to be considered." (Where applicable, evidence of valid registration by the competent Authority shall be attached)"

I, the undersigned, declare that the item originates in..... (Name of the country).

Signature.....

Name.....

Designation.....

Date.....

Stamp of the Organization.....

(To be submitted on the letter head of the manufacturing firm)

SECTION XIV: MANUFACTURER'S AUTHORIZATION FORM

To,

Security Paper Mill, Narmadapuram
A Unit of Security Printing & Minting
Corporation of India Limited
(Wholly Owned by Govt. of India)
Hoshangabad

Ref: Your Tender document No, dated

We,.....who are proven and reputable manufacturers of
..... (Name and description of the goods offered in the tender) having
factories at hereby authorize Messrs
(name and address of the agent) to submit a tender, process the same further and enter into a
contract with you against your requirement as contained in the above referred tender enquiry
documents for the above goods manufactured by us.

We further confirm that no supplier or firm or individual other than Messrs.....
..... (name and address of the above agent) is authorized to submit a
tender, process the same further and enter into a contract with you against your requirement
as contained in the above referred tender enquiry documents for the above goods
manufactured by us.

We also hereby extend our full warranty, as applicable as per clause 16 of the General
Conditions of Contract read with modification, if any, in the Special Conditions of Contract for
the goods and services offered for supply by the above firm against this tender document.

Yours faithfully,

.....
.....

[Signature with date, name, and designation]

for and on behalf of Messrs.....

Name & address of the manufacturers

*Note: This letter of authorization should be on the letter head of the manufacturing firm and
should be signed by a person competent and having the power of attorney to legally bind the
manufacturer.*

Checklist of Documents for Technical Bid

S. No.	Documents Required	Submitted (✓)
1	Weather applied for MSME (MSME certificate)	()
2	Certificate of Local Content as per Public Procurement (Preference to Make in India), Order 2017	()
3	Duly Seal & Signed: Technical Specifications	()
4	Buyer added Specific ATC Declarations (Buyer uploaded ATC document : Annexure-I, II, III)	()
5	Manufacturer/OEM Authorization Certificate	()